



Schematic diagrams



INNOWAVE

→ Fresh Air Handling Unit

Device Description	Location	QTY	DDC #	Notes
FAHU-1A	-	1	-	
FAHU-2A	-	1	-	
FAHU-3A	-	1	-	
FAHU-4A	-	1	-	



INNOWAVE

DGP-P1A-FAHU

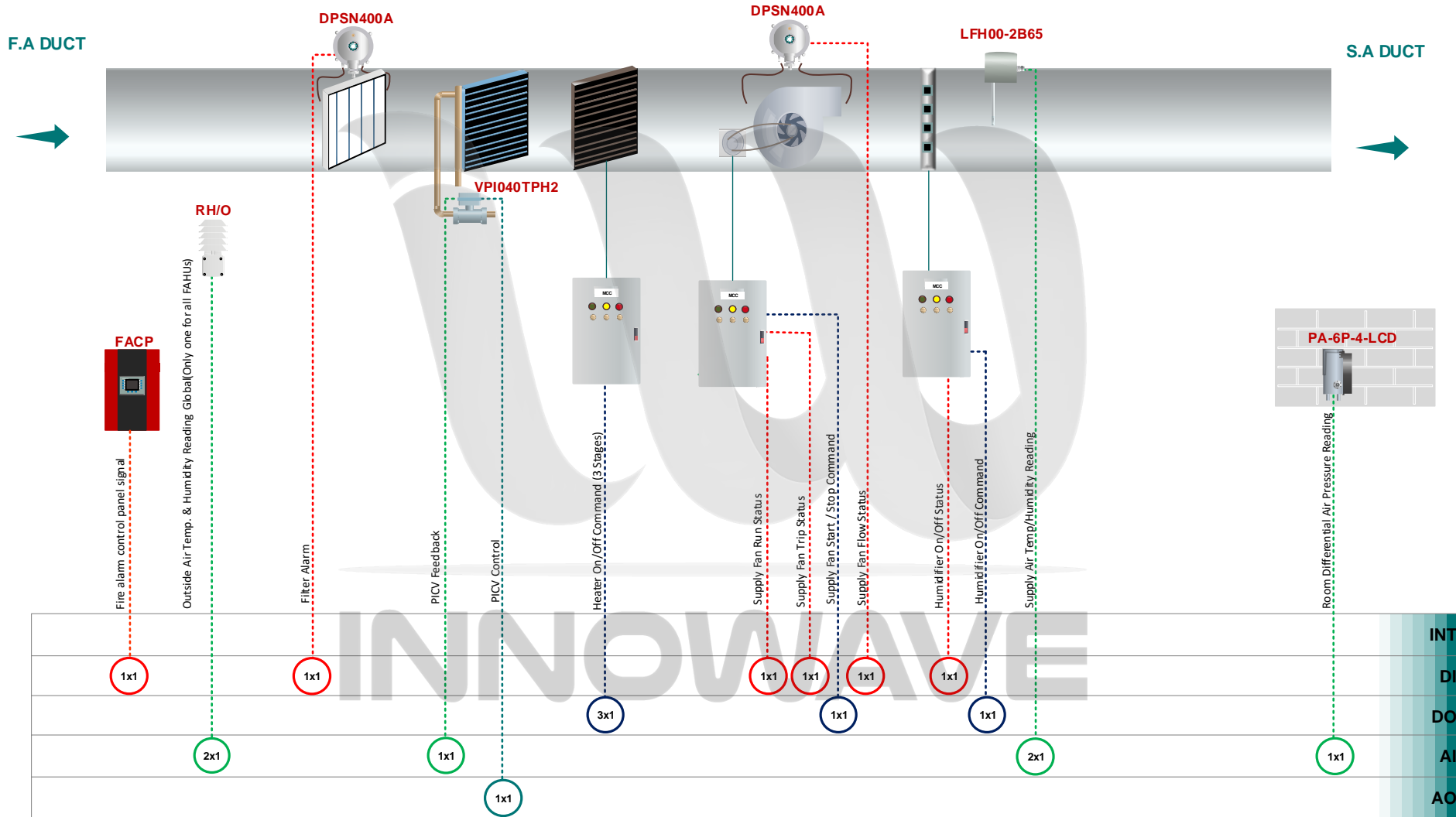

Fuel System

Device Description	Device Tag	Location	QTY	DDC #	Notes
Generator	GEN-1A	-	1	-	
Generator	GEN-1B	-	1	-	
Generator	GEN-2A	-	1	-	
Generator	GEN-2B	-	1	-	
Generator	GEN-3A	-	1	-	
Generator	GEN-3B	-	1	-	
Generator	GEN-4A	-	1	-	
Generator	GEN-4B	-	1	-	
Generator	GEN-OB	-	1	-	

INNOWAVE

Fuel System

Device Description	Device Tag	Location	QTY	DDC #	Notes
Fuel Pumps	FP-1A-01 & FP-1A-02	-	2		
Bulk Fuel Tank	FMT-1A	-	1		
Fuel Polisher (Solenoid Valves)	SOV-GF-1A, SOV-GF-2A, SOV-GF-1B & SOV-GF-2B	-	4		
Fuel Drain	FDP-1A.....6B	-	12		
Day Tanks	DT-GEN-1A.....6B	-	12		
SOV & Drain Valves	SOV-1A,MV-DR-1A....SOV-6B,MV-DR-6B	-			
Fuel Pumps	FP-1B-01 & FP-1B-02	-	2		
Bulk Fuel Tank	FMT-1B	-	1		
Generator	GEN-OB	-	1		
Fuel Pumps	FP-OB-01	-	1		
Main Tank	FST-OB		1		

INNOWAVE

Fuel System

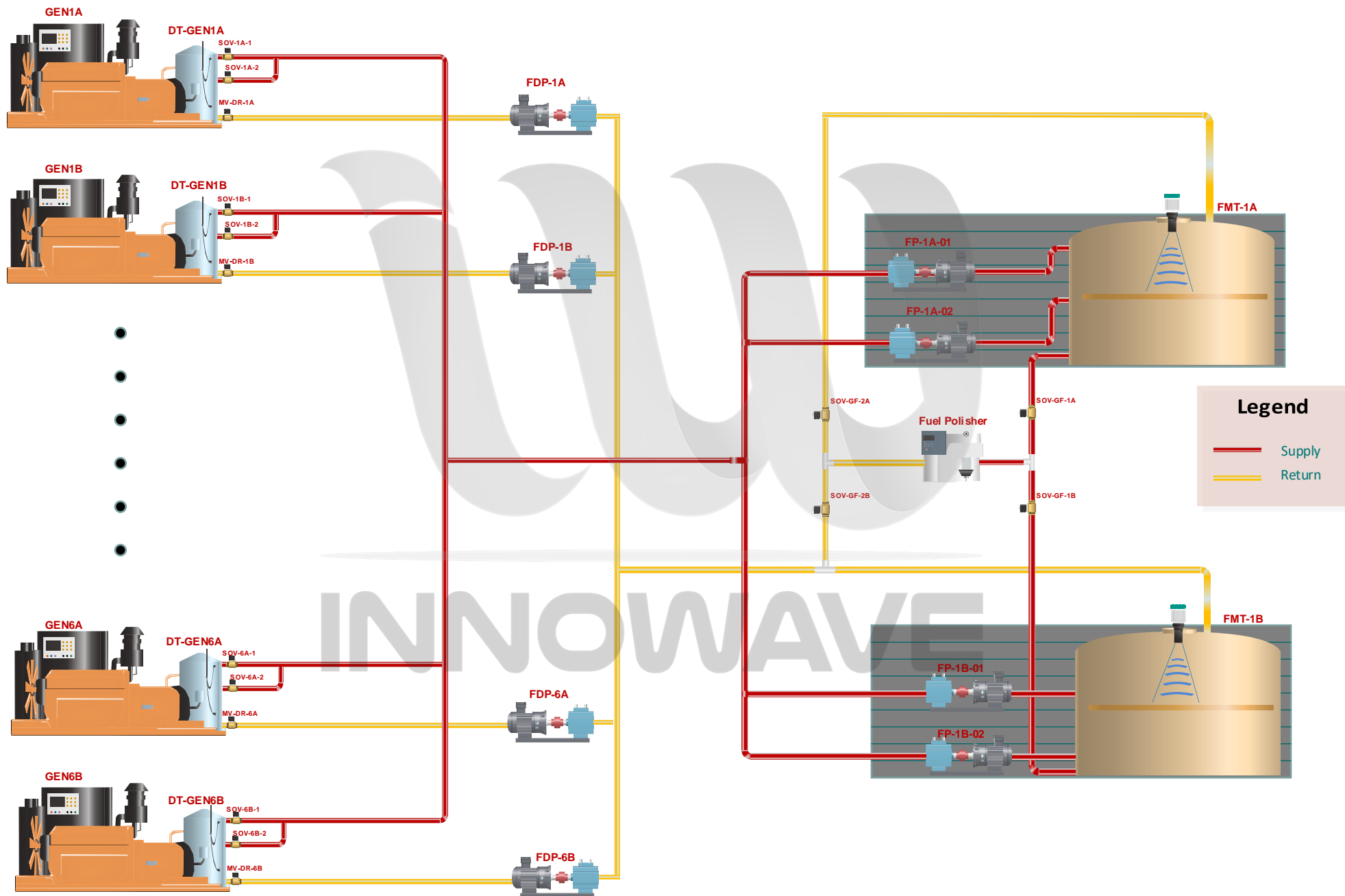

Fuel System (Generator, Generator DT, Valves)

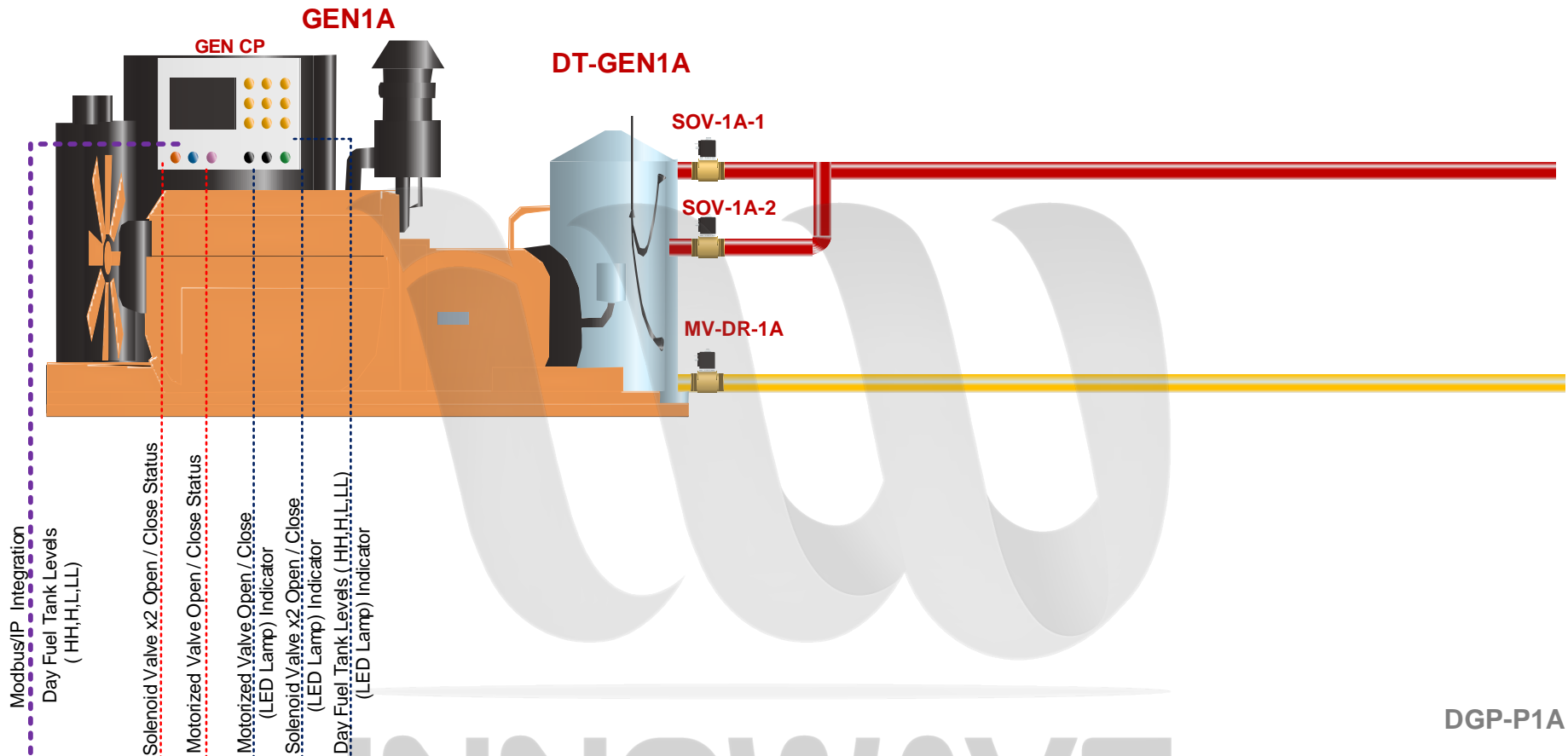

- Modbus/IP Integration
- Day Fuel Tank Levels (HH,H,L,LL)
- Solenoid Valve x2 Open / Close Status
- Motorized Valve Open / Close Status
- Motorized Valve Open / Close (LED Lamp) Indicator
- Solenoid Valve x2 Open / Close (LED Lamp) Indicator
- Day Fuel Tank Levels (HH,H,L,LL) (LED Lamp) Indicator

50 x1	DGP-P1A	INT
	DGP-FOS-1A	INT
1x2		DI
1x1		DO
1x1		AI
1x2		AO
4x1		

Fuel System (Filling Pump, Bulk Tank)

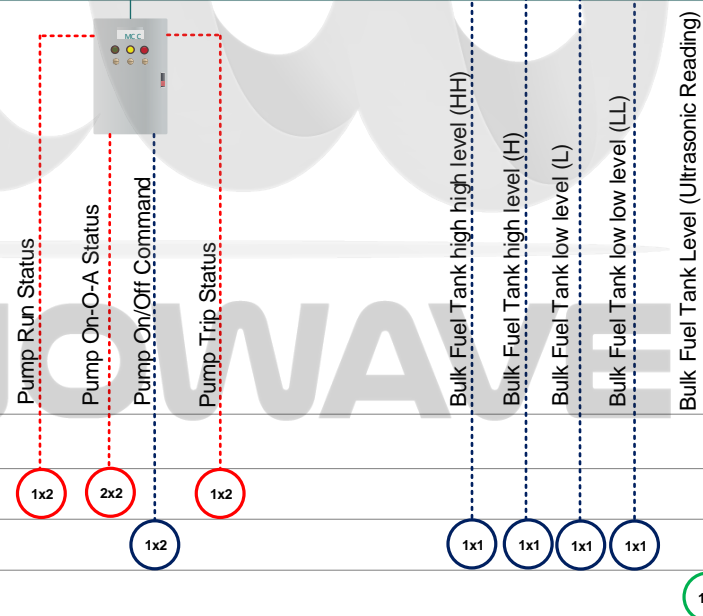
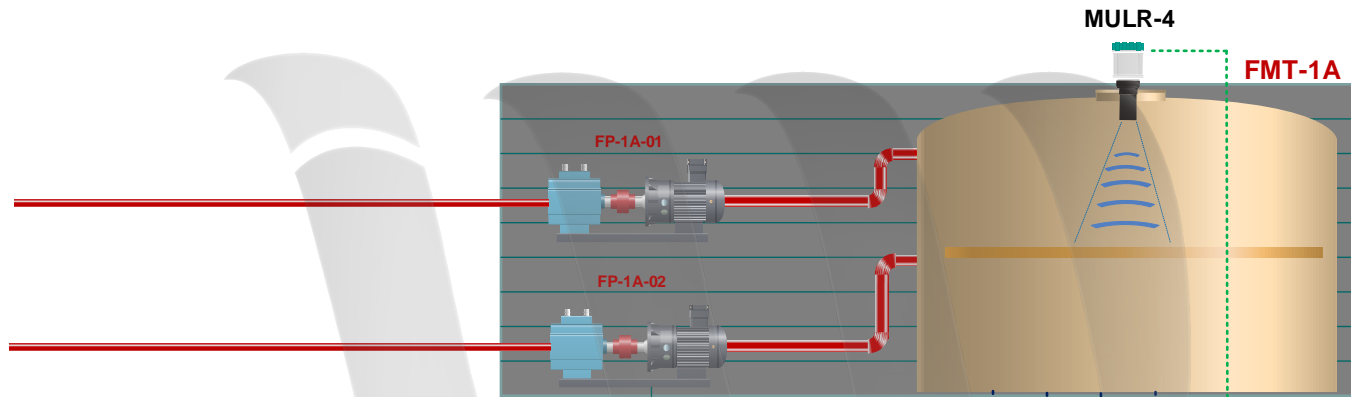

DGP-FOS-1A

Signal	Quantity	Type
Pump Run Status	1x2	DI
Pump On-O-A Status	2x2	DI
Pump On/Off Command	1x2	DO
Pump Trip Status	1x2	DI
Bulk Fuel Tank high level (HH)	1x1	DI
Bulk Fuel Tank high level (H)	1x1	DI
Bulk Fuel Tank low level (L)	1x1	DI
Bulk Fuel Tank low level (LL)	1x1	DI
Bulk Fuel Tank Level (Ultrasonic Reading)	1x1	AI

Chiller System

Device Description	Device Tag	Location	QTY	DDC #	Notes
Buffer Tanks	TES-1A to TES-4B (TES-5A to 6B for Day 3)	-	8	-	
Chillers	CH-PL1-1,2,3,4,5,6,7,8AB	-	8	-	
Primary Chilled Water Pumps	PCWP-PL1-1,2,3,4,5,6,7,8	-	8	-	
Secondary Chilled Water Pumps	SCWP-PL1-1,2,3,4,5,6,7,8	-	8	-	

INNOWAVE

Chilled Water System

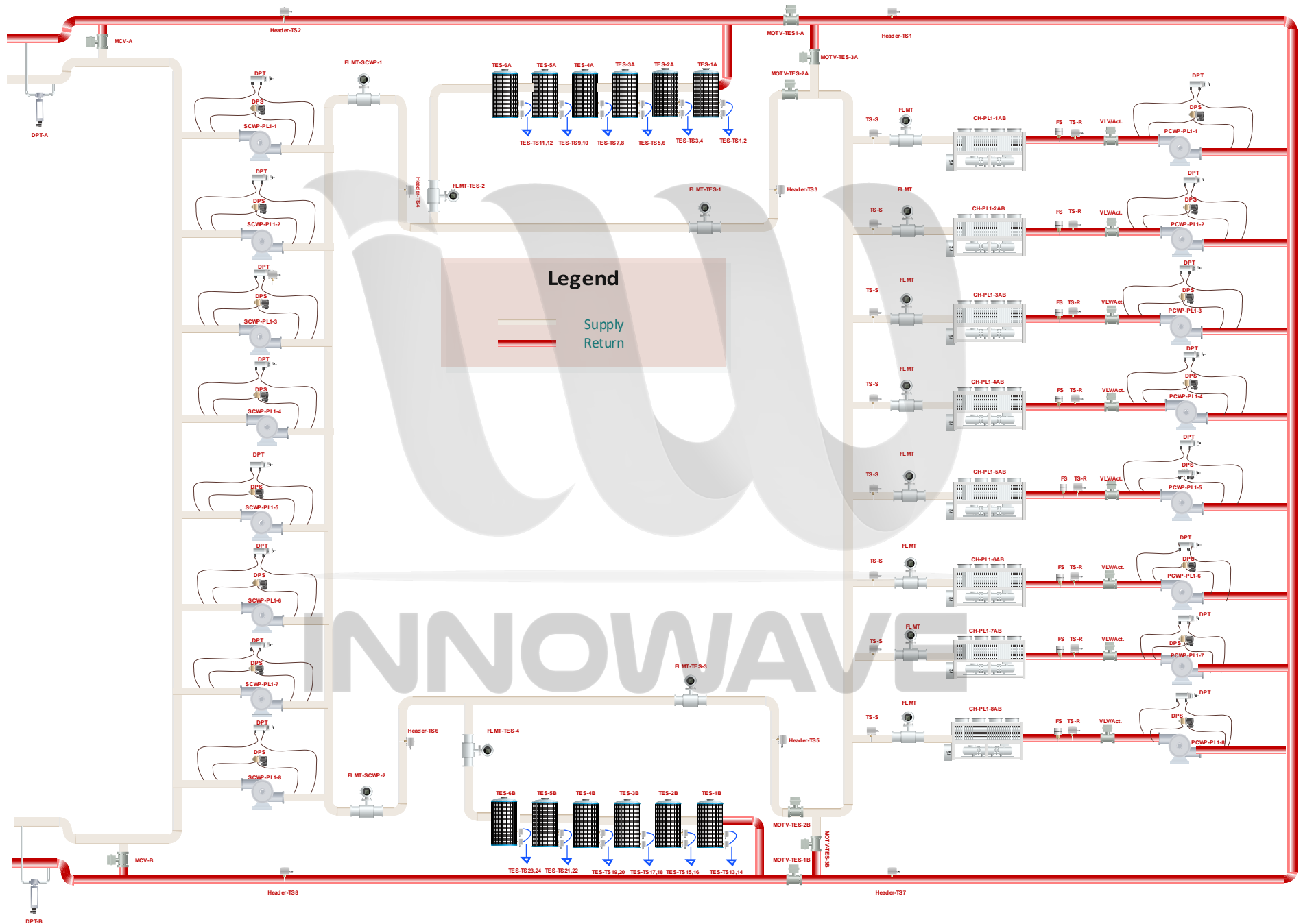

Chilled Water System (Chilled Water Network)

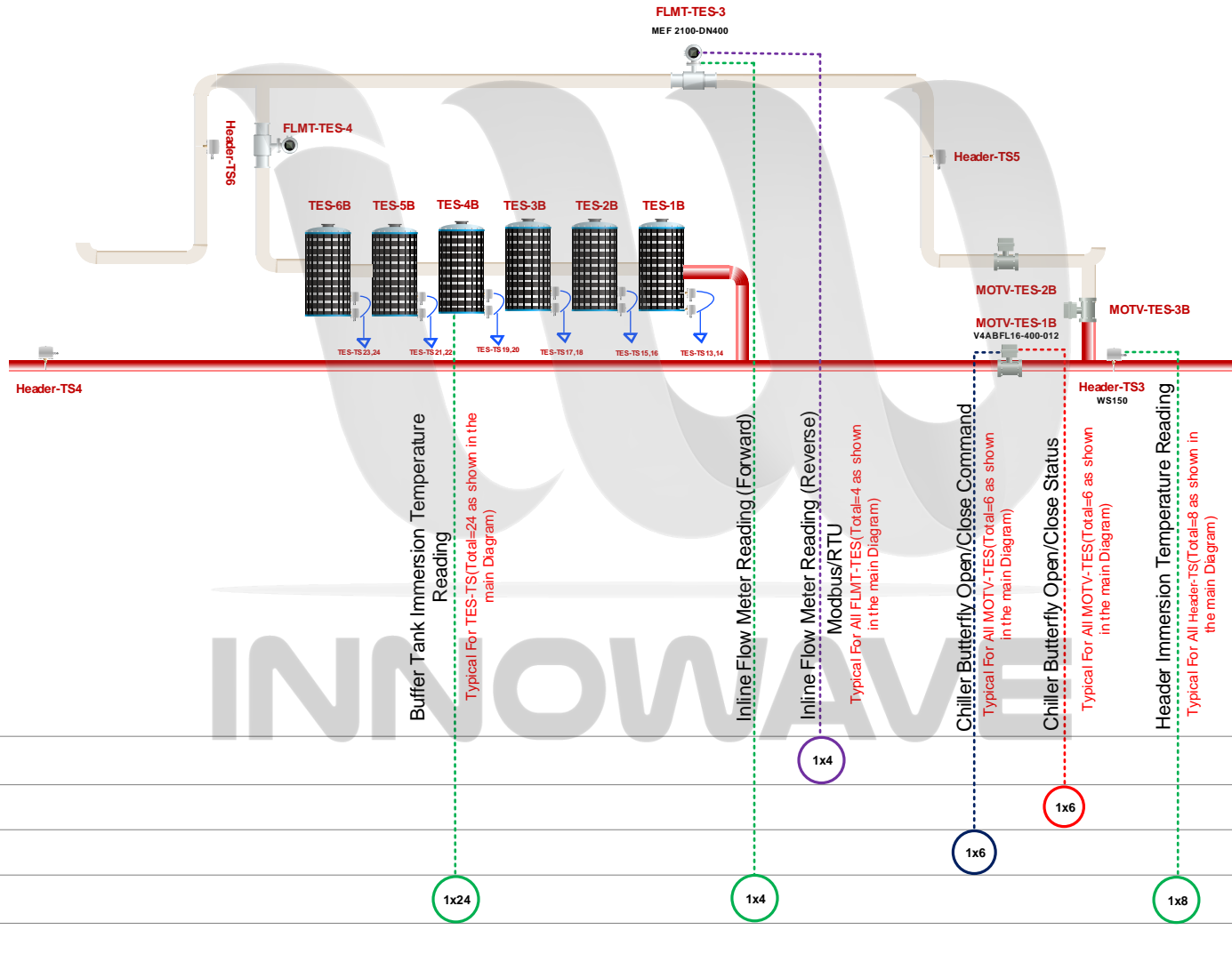

Chilled Water System (Primary Side)

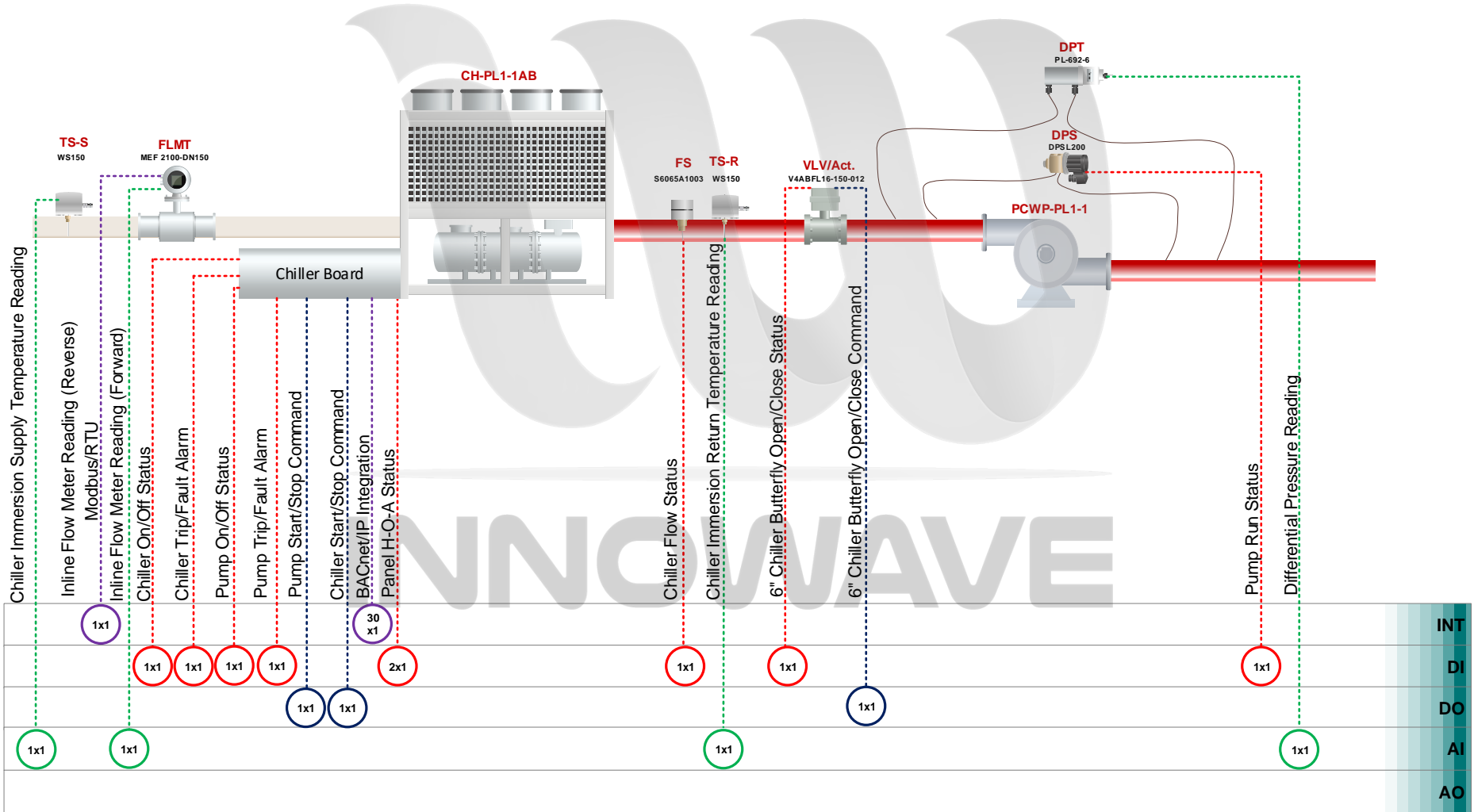

Chilled Water System (Secondary Side)

