



Innovation Wave For Engineering Services

Address Jordan-Amman-Princess Basmah St.-Methaq Tower
E-mail info@innowave-me.com
Phone no. +962 7 9109 0333

Customer

Customer name here

Contractor

Contractor name here

Manufacturer (Company)

Innovation Wave For Engineering Services

Project Description

S.K.U.A

Drawing Title

DDC12

Number of pages 14

Revision No.	Revision Name	Date	Approved by

Customer
Customer Name & Logo Here

Contractor
Contractor Name & Logo Here

Company
Innovation Wave For Engineering Services



S.K.U.A
DDC12
Title Page

Page 1 / 14

Layout Symbol	Schematic Symbol	Description
		Transformer 220VAC/24VAC
		24VDC Power Supply
		Utility Socket
		2 Pole MCB
		1 Pole Fuse Switch
		2 Pole Relay Coil & Contact
		Feed Through Terminal 4mm ²
		Feed Through Terminal 6mm ²

Layout Symbol	Schematic Symbol	Description
		Earth Feed Through Terminal 6mm ²
		Double Level Terminal 4mm ²

+24VDC
/ 8.G:6

Cross Reference:
/ X.Y:Z

X: Page number
Y: Column number
Z: Row Number

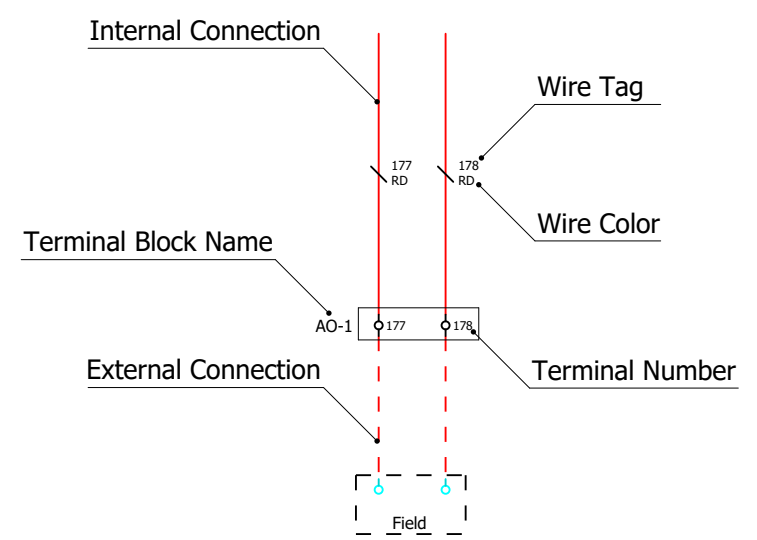

Revision No.	Revision Name	Date	Approved by

Customer
Customer Name & Logo Here

Contractor
Contractor Name & Logo Here

Company
Innovation Wave For
Engineering Services

S.K.U.A

Summarized parts list

Device Tag	Part number	Quantity	Designation	Manufacturer
I/O Terminals	CDL4UN(I.S)	27	Double Screw Terminal,Feed Through, Conductor cross section stranded, 0.2 - 4.0mm ² . Dimensions (L x W x H), 57 X 6 X 59.5 mm. Colour "grey", 800V/32A	Connectwell
PIN	CTS6U	2	Conductor cross section stranded, 0.5 - 6 mm ² . Dimensions (L x W x H), 43 x 8 x 47.8 mm. Colour "grey", 1000 V/41A	Connectwell
PIN	CGT6N	2	Conductor cross section stranded, 0.2 - 6.0mm. Dimensions (L x W x H), 54.5 x 8 x 48.2mm. Colour "green/yellow"	Connectwell
24VAC;24VDC;230VAC	CTS4UN	8	Screw Terminal, Feed Through, Conductor cross section mm ² stranded, 0.2 - 4mm ² Dimensions (L x W x H), 43 x 6 x 46.2mm Colour "grey", 1000 V/32A	Connectwell
Socket	617643	1	Socket outlet - 1 gang double pole switched - 13 A 250 V~	Legrand
T		1	230/24 VAC transformer	Himel
F1	A9N15636	1	Acti 9 STI - fuse-disconnector STI - 1 pole - 25 A - for fuse 10.3 x 38 mm	Schneider
FM	A9F44210	1	Acti9 iC60N 2P 10A C Miniature Circuit breaker	Schneider
PS	LP1100D-24MDA	1	DC Power Supply 24V, 4.2A 100w. Din Rail / Screw Mouting. Input range: 90~132/180~264VAC(Selectable), 220~380VDC. Input frequency: 47~63Hz. Monitor Display for Output Voltage	ReignPower
AI-1;AI-2	IB IL AI 4/U/0-10-ECO	2	Inline, Analog input terminal, Analog inputs: 4, 0 V ... 10 V	Phoenix Contact
AO-1	IB IL AO 4/U/0-10-ECO	1	Inline ECO, Analog output terminal, Analog outputs: 4, 0 V ... 10 V	Phoenix Contact
DI-1	IB IL 24 DI 8/HD-ECO	1	Inline ECO, Digital input terminal, Digital inputs: 8, 24 V DC	Phoenix Contact
ILC	ILC 2050 BI	1	Inline controller, four LAN, two USB and two RS-485 interfaces, The controller can be extended with numerous Inline modules for digital and analog I/Os and for all standard bus systems.	Phoenix Contact
RTD-1	IB IL RTD 4/PT1000-ECO	1	Inline ECO, Temperature measurement terminal, Analog RTD inputs: 4 (Pt 1000)	Phoenix Contact
EN	47-SB606025D	1	Metal Enclosures Single Door, IP65, Hight x Width x Depth : 600x600x250 (mm)	Alfanar

INNOWAVE

0

1

2

3

4

5

6

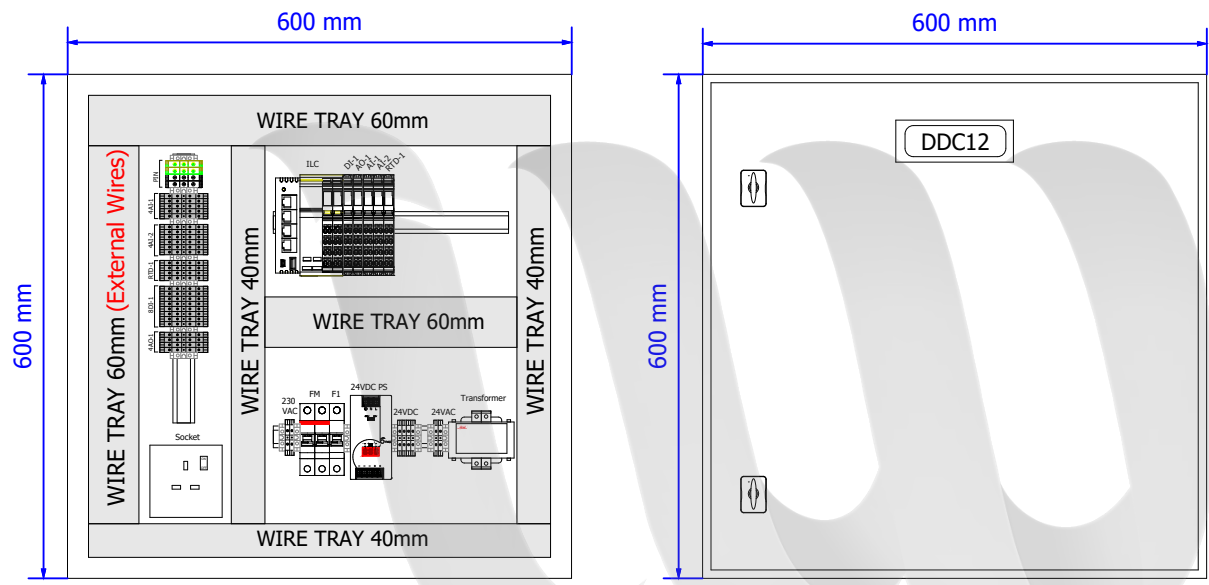

Front View (Mounting Plate)

Front View (Door Closed)

INNOWAVE

Panel Profile	
Dimensions (HxWxD)	(600x600x250)
Protection Degree	IP65
Cable Entry	Top
* All dimensions are in mm.	

			Edit date	
			Edited by	
			Checked by	
Revision No.	Revision Name	Date	Approved by	

Customer
Customer Name & Logo Here

Contractor
Contractor Name & Logo Here

Company
 Innovation Wave For
 Engineering Services



S.K.U.A

DDC12	
Panel Layout	Page 6 / 14

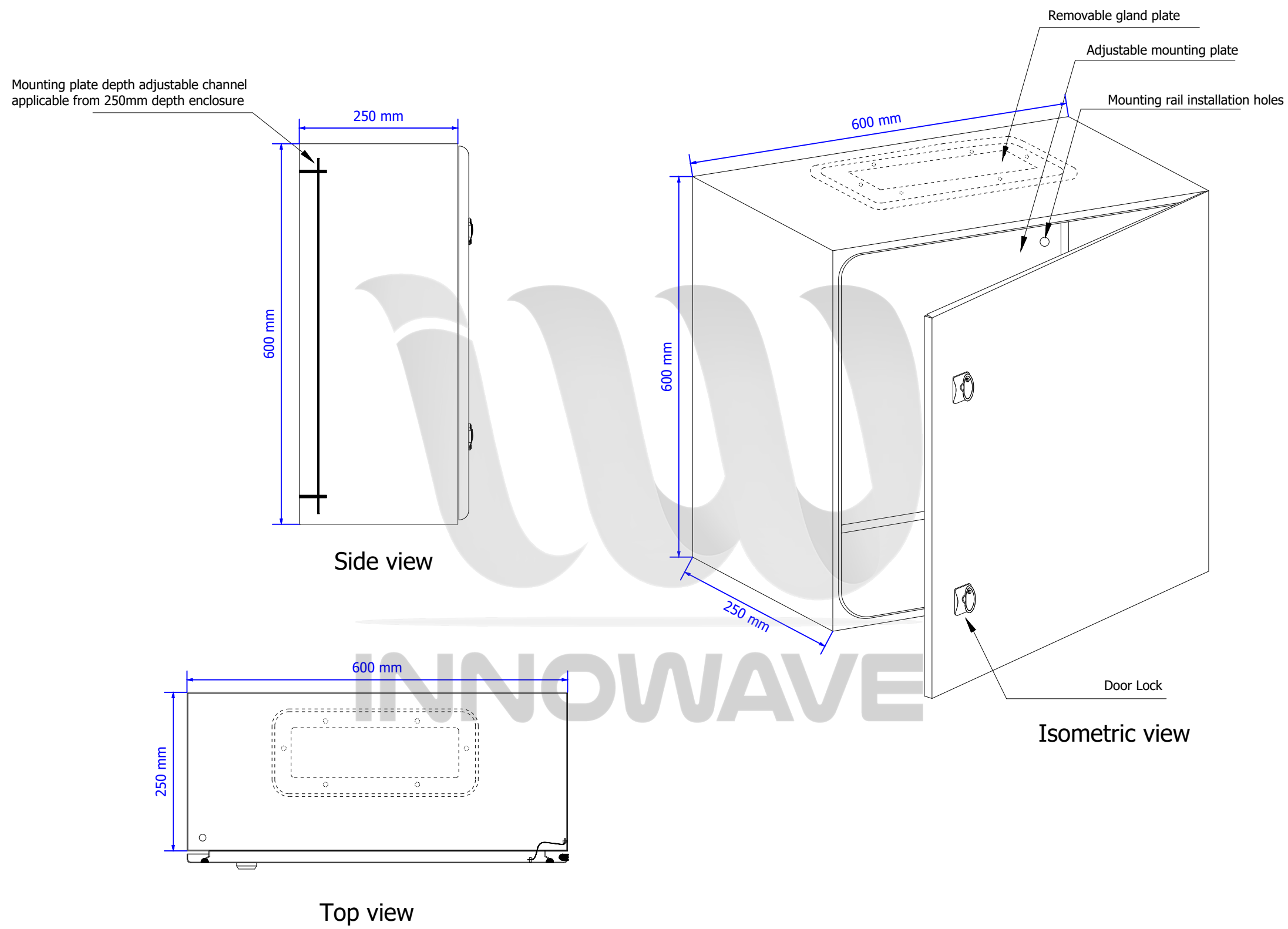

			Edit date
			Edited by
			Checked by
Revision No.	Revision Name	Date	Approved by

Customer
Customer Name & Logo Here

Contractor
Contractor Name & Logo Here

Company
 Innovation Wave For Engineering Services



S.K.U.A

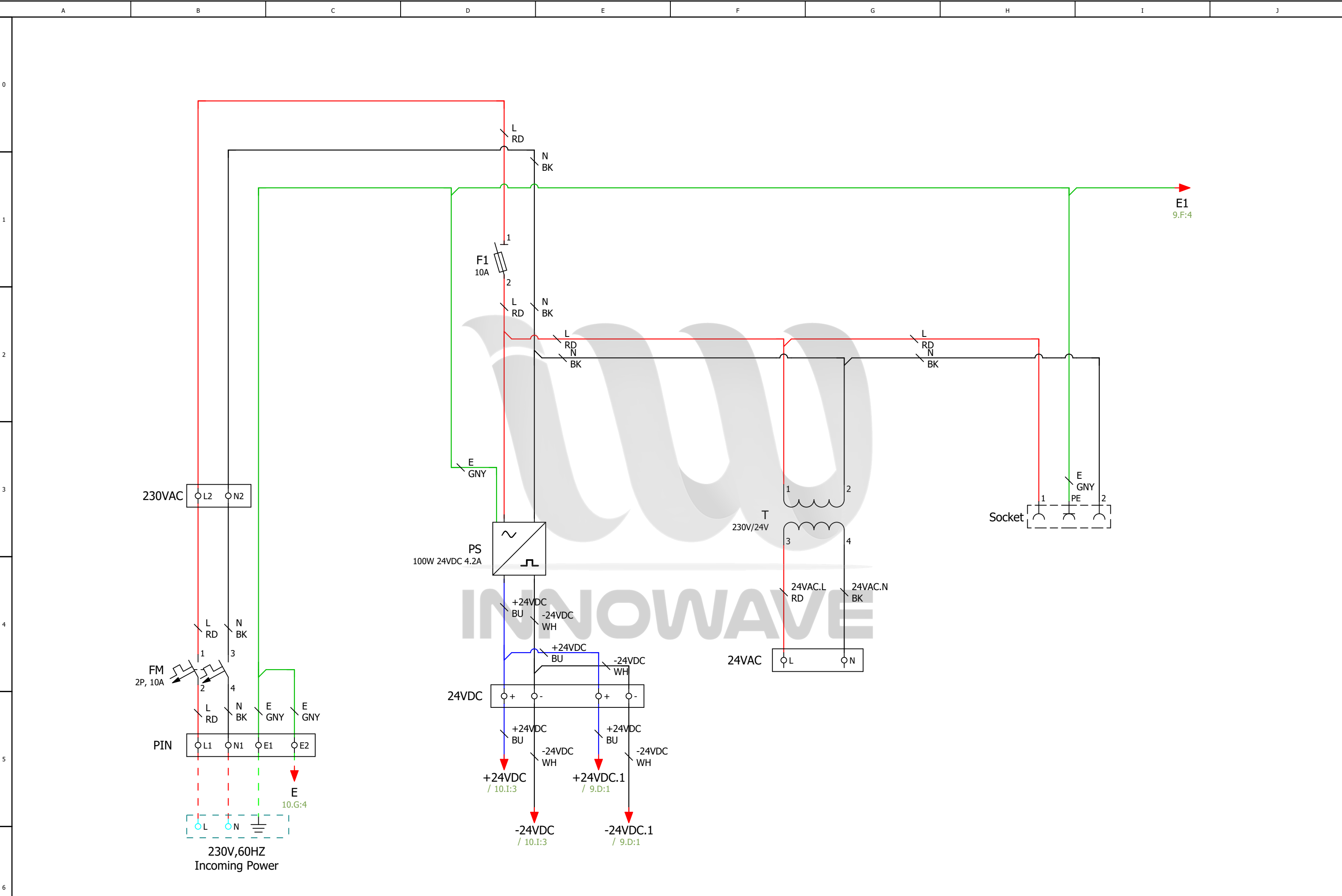

Revision No.	Revision Name	Date	Approved by

Customer
 Customer Name & Logo Here

Contractor
 Contractor Name & Logo Here

Company
 Innovation Wave For Engineering Services

S.K.U.A

0

1

2

3

4

5

6

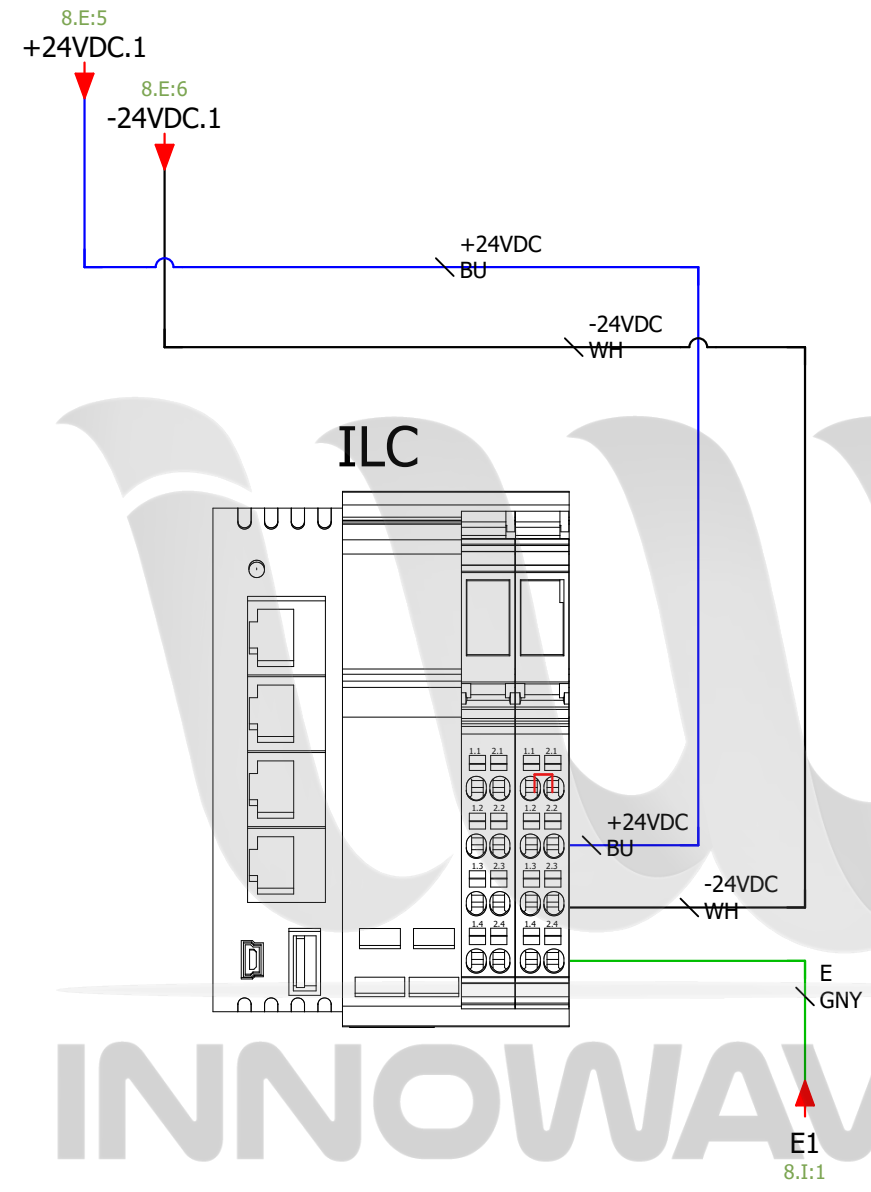

			Edit date	
			Edited by	
			Checked by	
Revision No.	Revision Name	Date	Approved by	

Customer
Customer Name & Logo Here

Contractor
Contractor Name & Logo Here

Company
 Innovation Wave For Engineering Services



S.K.U.A

0

1

2

3

4

5

6

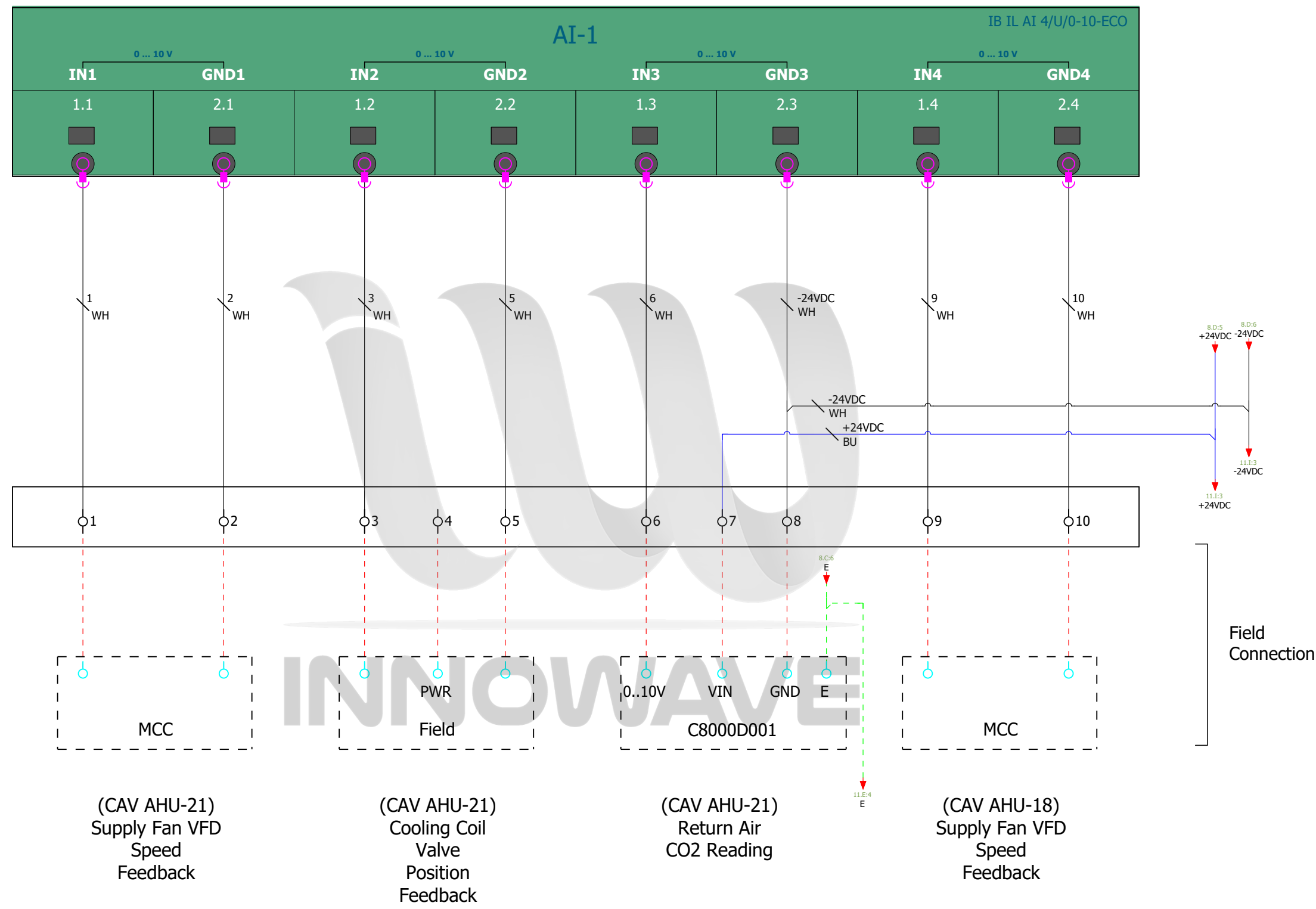

Revision No.	Revision Name	Date	Approved by

Customer
 [Customer Name & Logo Here]

Contractor
 [Contractor Name & Logo Here]

Company
 Innovation Wave For Engineering Services

S.K.U.A

0

1

2

3

4

5

6

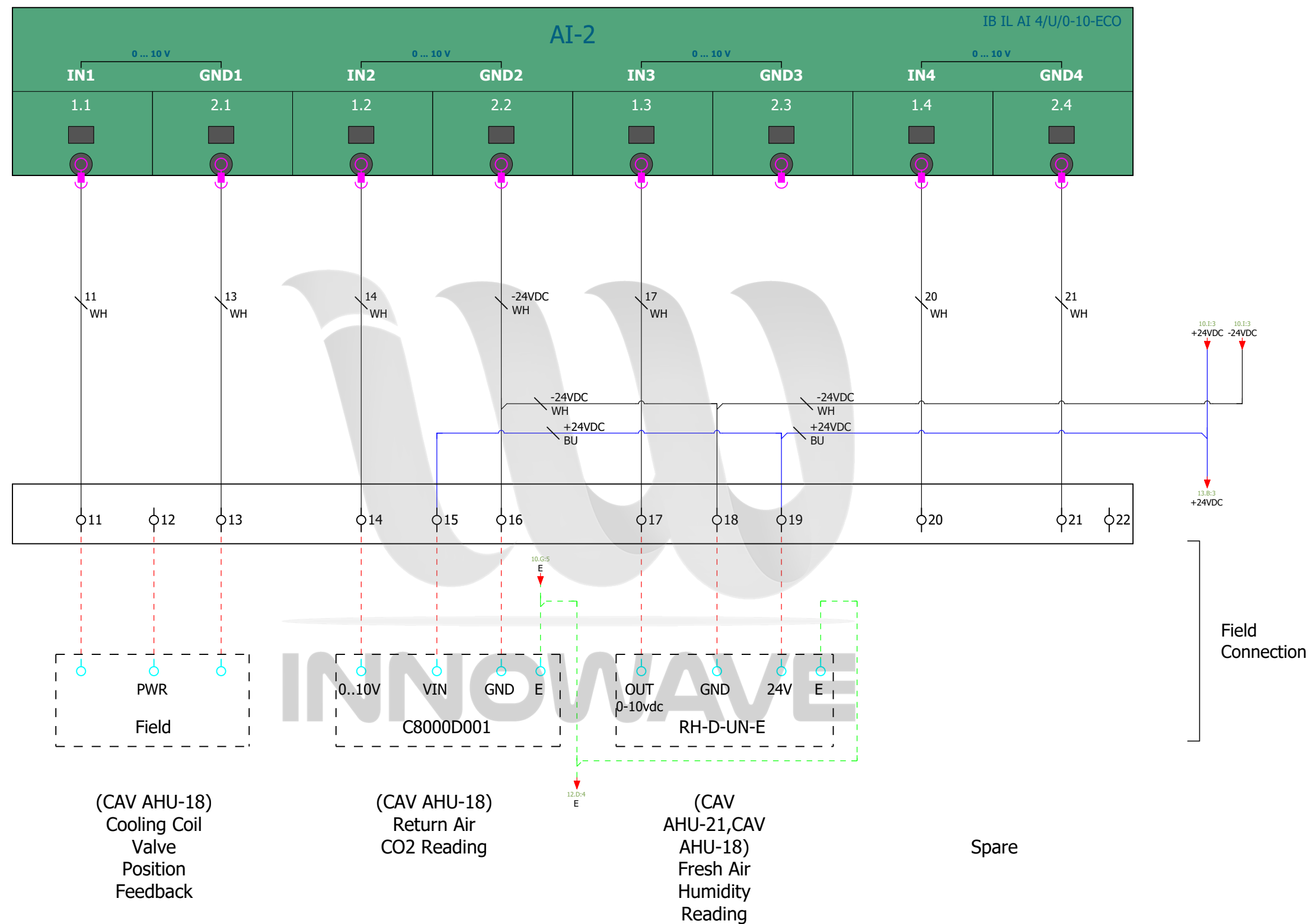

Revision No.	Revision Name	Date	Approved by

Customer
 [Customer Name & Logo Here]

Contractor
 [Contractor Name & Logo Here]

Company
 Innovation Wave For Engineering Services

S.K.U.A

0

1

2

3

4

5

6

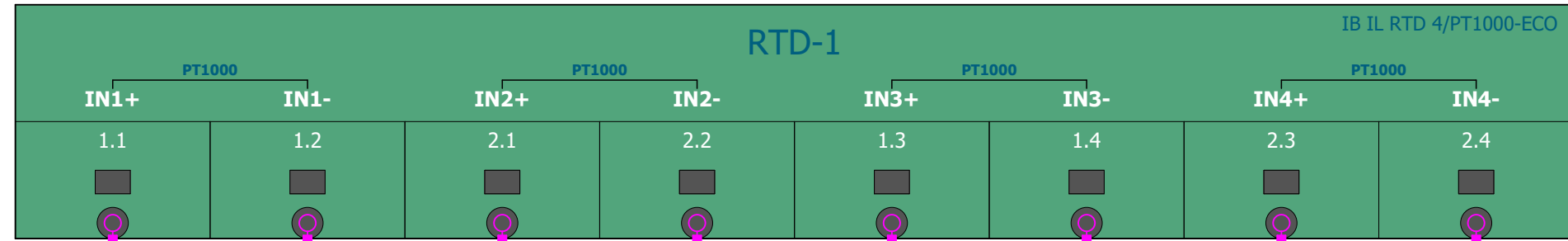

RTD-1



Field Connection

(CAV AHU-21)
Mixing Air
Temperature
Reading

(CAV AHU-18)
Mixing Air
Temperature
Reading

(CAV
AHU-21,22)
Fresh Air
Temperature
Reading

Spare

			Edit date	
			Edited by	
			Checked by	
Revision No.	Revision Name	Date	Approved by	

Customer
Customer Name & Logo Here

Contractor
Contractor Name & Logo Here

Company
Innovation Wave For
Engineering Services



S.K.U.A

0

1

2

3

4

5

6

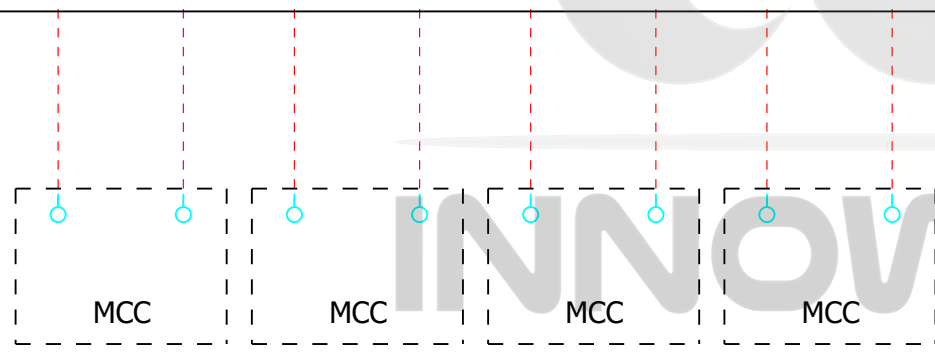
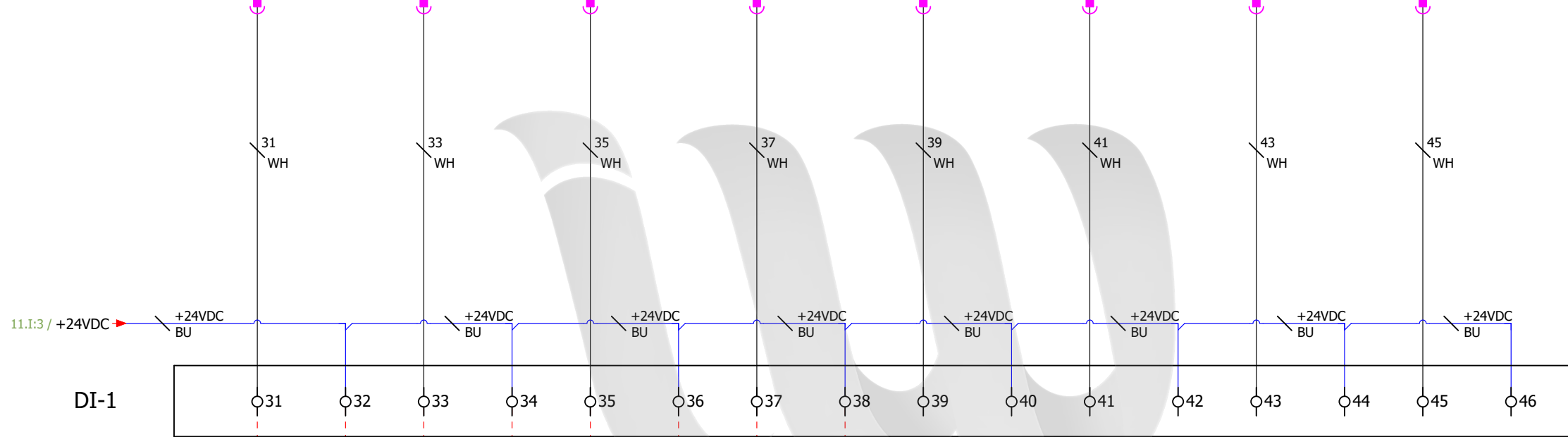
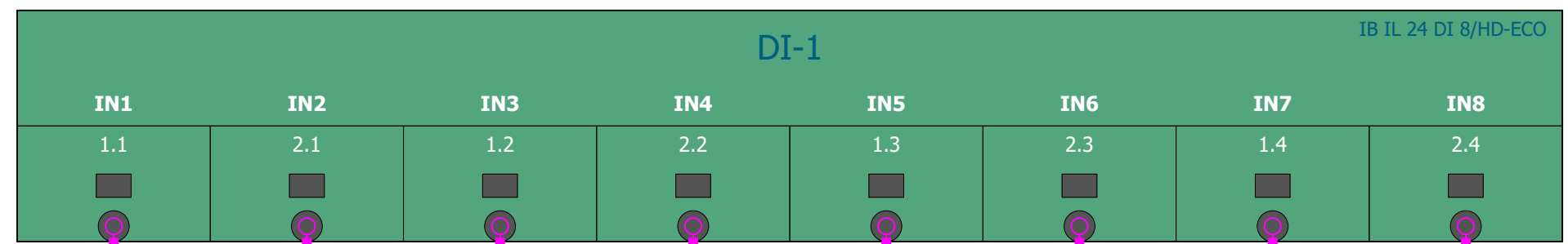

(CAV AHU-21) Supply Fan Run Status (CAV AHU-21) Supply Fan Bypass Selector Switch Status (CAV AHU-18) Supply Fan Run Status (CAV AHU-18) Supply Fan Bypass Selector Switch Status Spare Spare Spare Spare

Field Connection

Revision No.	Revision Name	Date	Approved by

Customer
Customer Name & Logo Here

Contractor
Contractor Name & Logo Here

Company
 Innovation Wave For Engineering Services

S.K.U.A

0

1

2

3

4

5

6

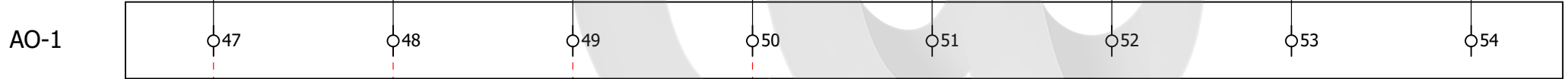
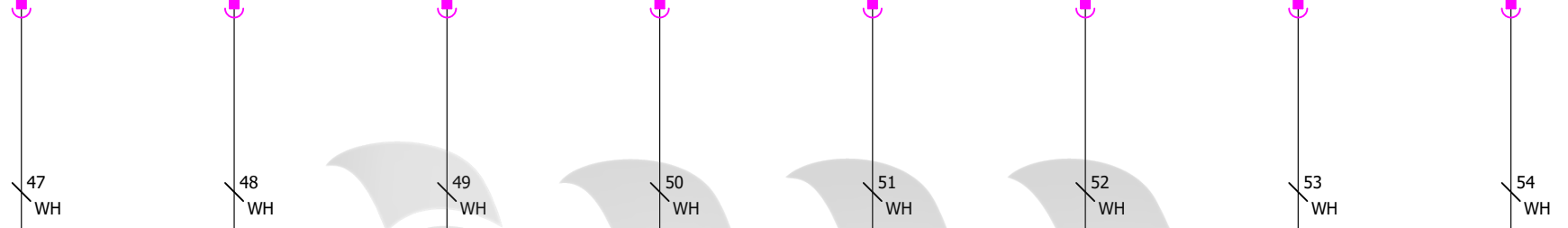
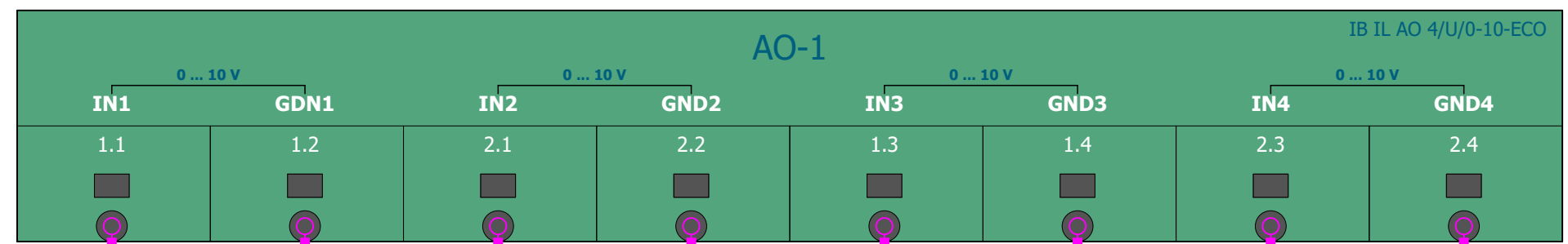

Field Connection

(CAV AHU-21)
Supply Fan VFD
Speed Control

(CAV AHU-18)
Supply Fan VFD
Speed Control

Spare

Spare



			Edit date
			Edited by
			Checked by
Revision No.	Revision Name	Date	Approved by

Customer
Customer Name & Logo Here

Contractor
Contractor Name & Logo Here

Company
Innovation Wave For
Engineering Services

S.K.U.A