



## Innovation Wave For Engineering Services

Address Jordan-Amman-Princess Basmah St.-Methaq Tower  
 E-mail info@innowave-me.com  
 Phone no. +962 7 9109 0333

Customer

Customer name here

Contractor

Contractor name here

Manufacturer (Company)

Innovation Wave For Engineering Services

Project Description

S.K.U.A

Drawing Title

CP  
Control Panel

Number of pages 20

			Edit date	
			Edited by	
			Checked by	
Revision No.	Revision Name	Date	Approved by	

**Customer**  
 Customer Name & Logo Here

**Contractor**  
 Contractor Name & Logo Here

**Company**  
 Innovation Wave For Engineering Services



S.K.U.A

CP	
Control Panel	
Title Page	Page 1/20







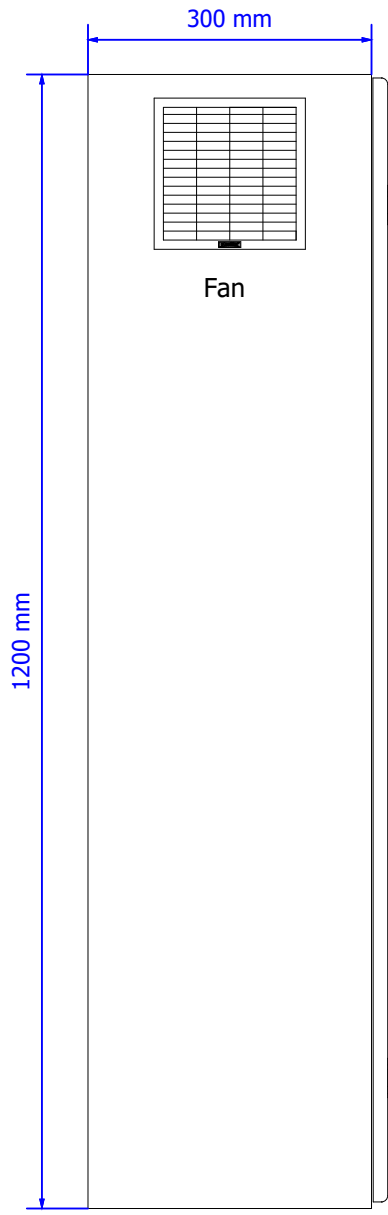

Left Side View

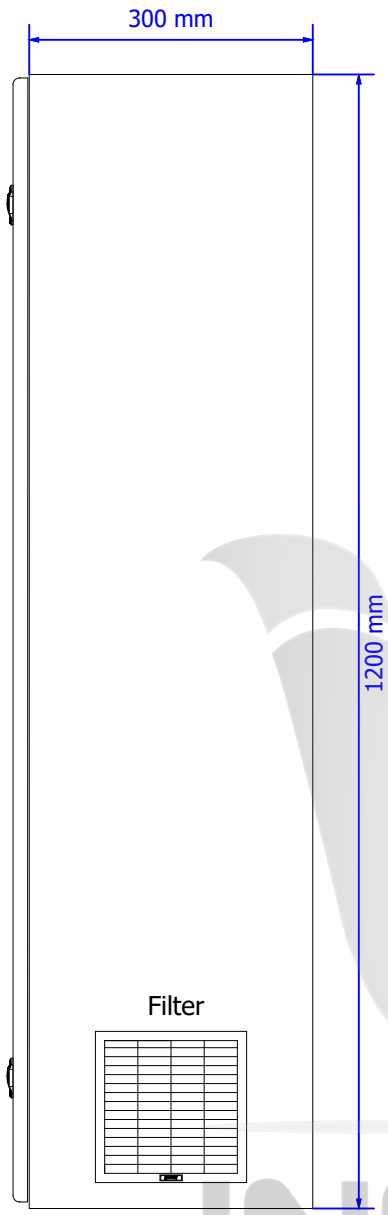

Right Side View

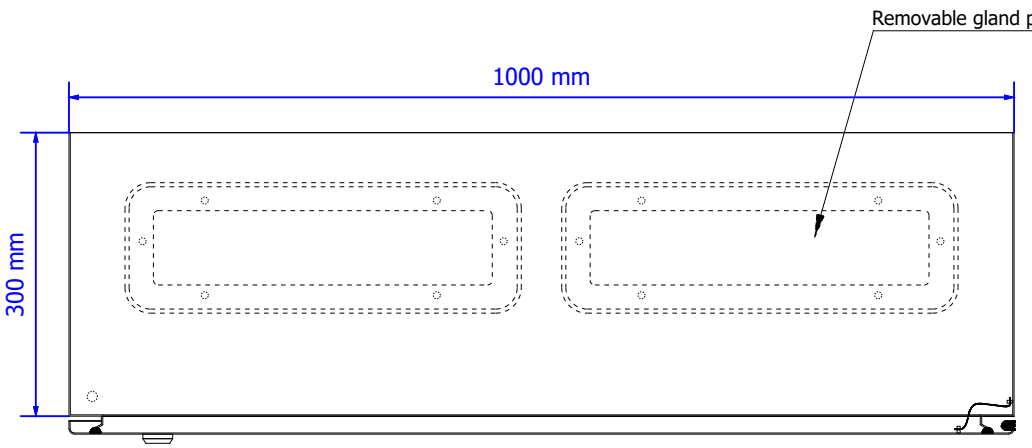

Bottom View

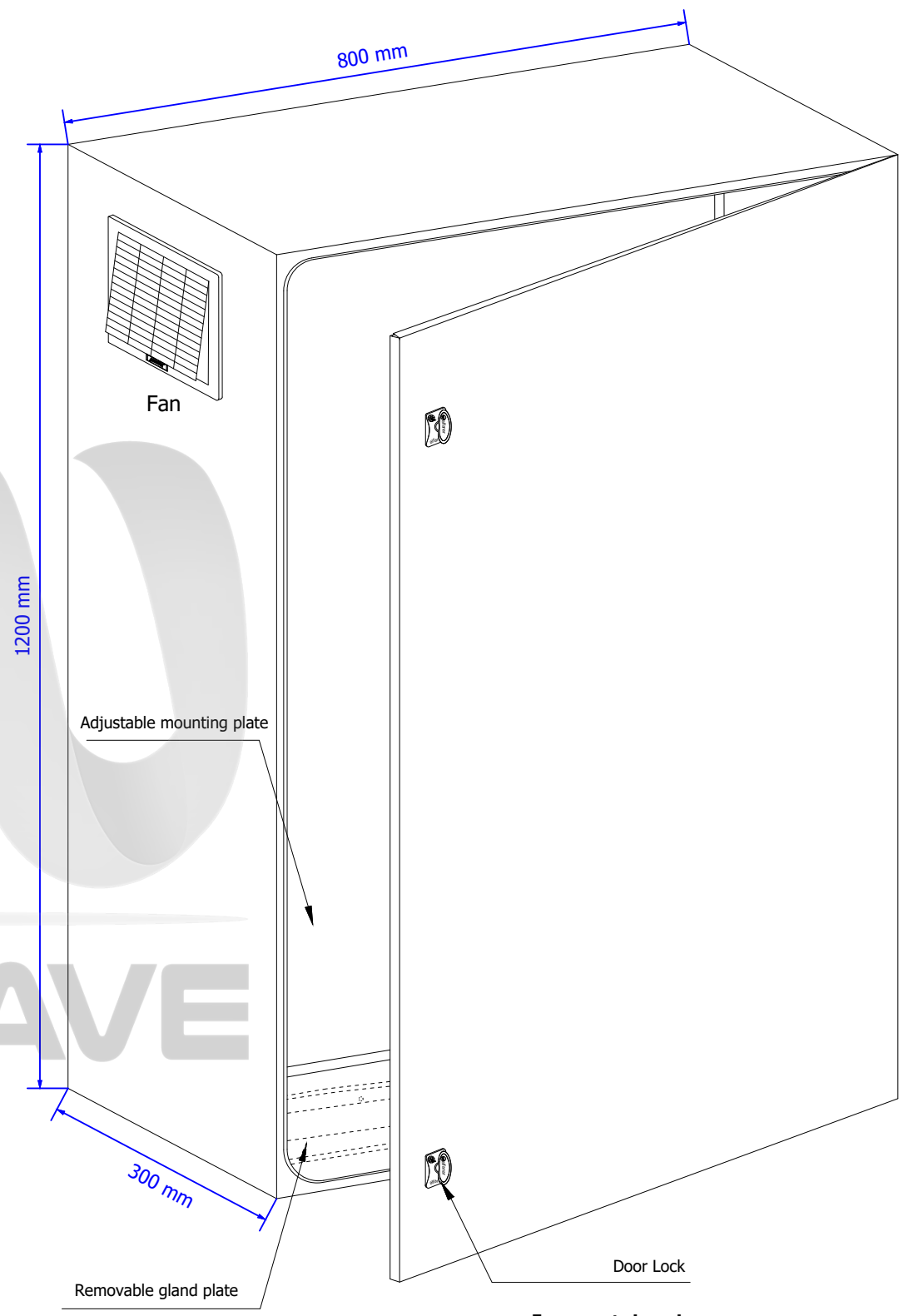

Isometric view

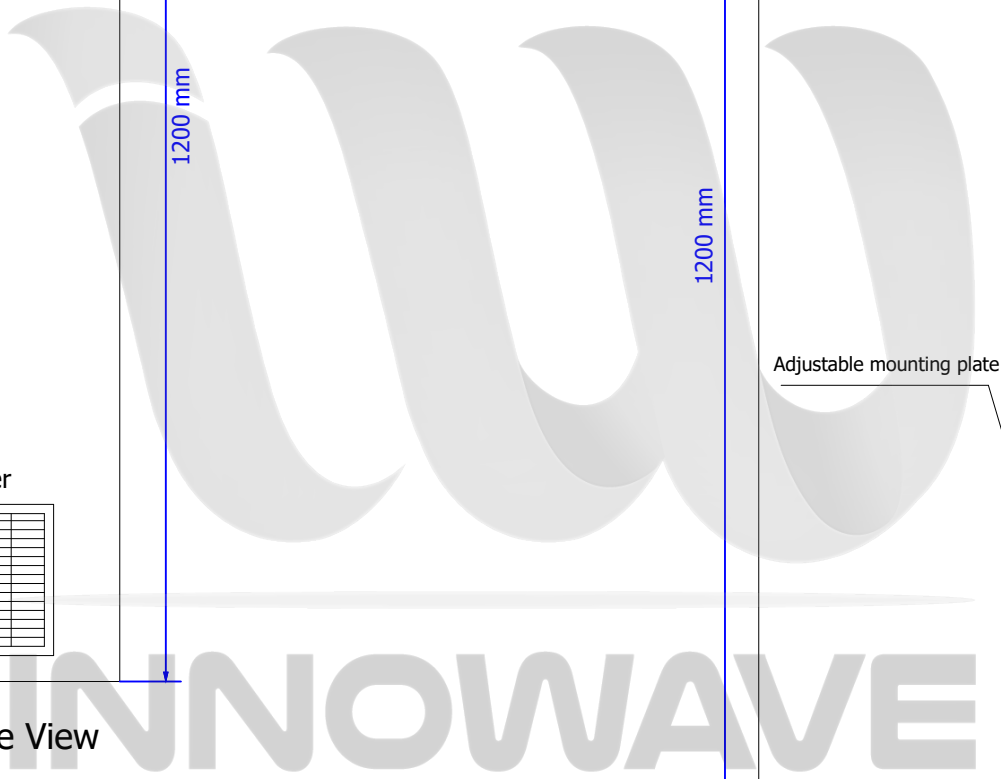

Revision No.	Revision Name	Date	Approved by

**Customer**  
 [Customer Name & Logo Here]

**Contractor**  
 [Contractor Name & Logo Here]

**Company**  
 Innovation Wave For Engineering Services  

S.K.U.A  
 Control Panel  
 Panel Layout

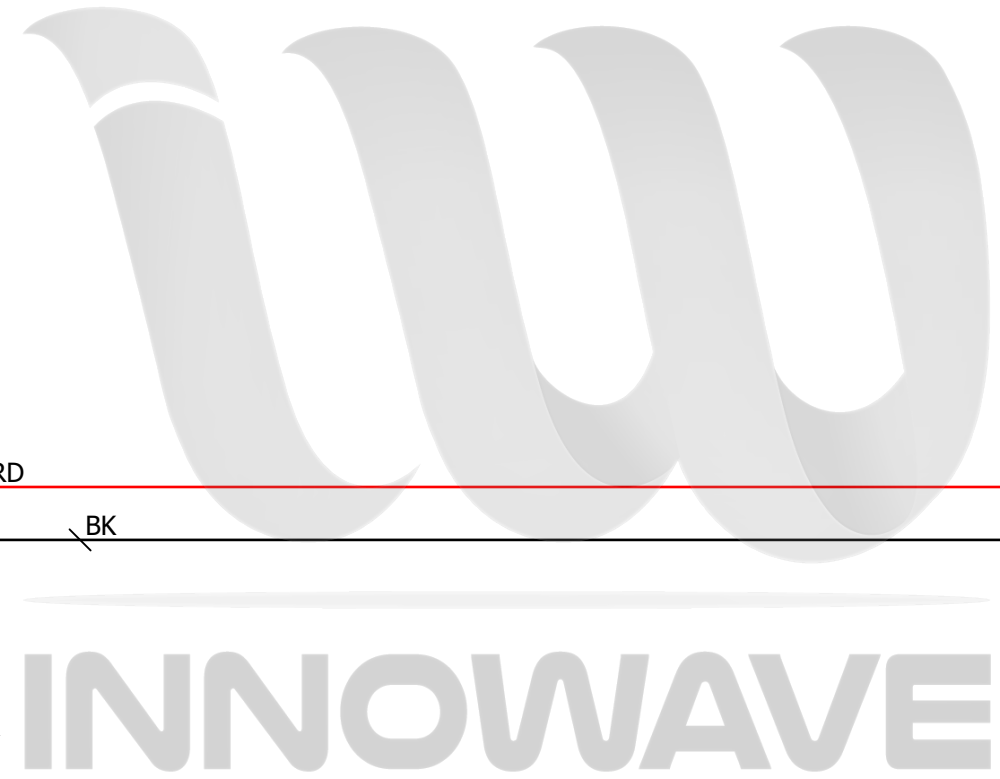
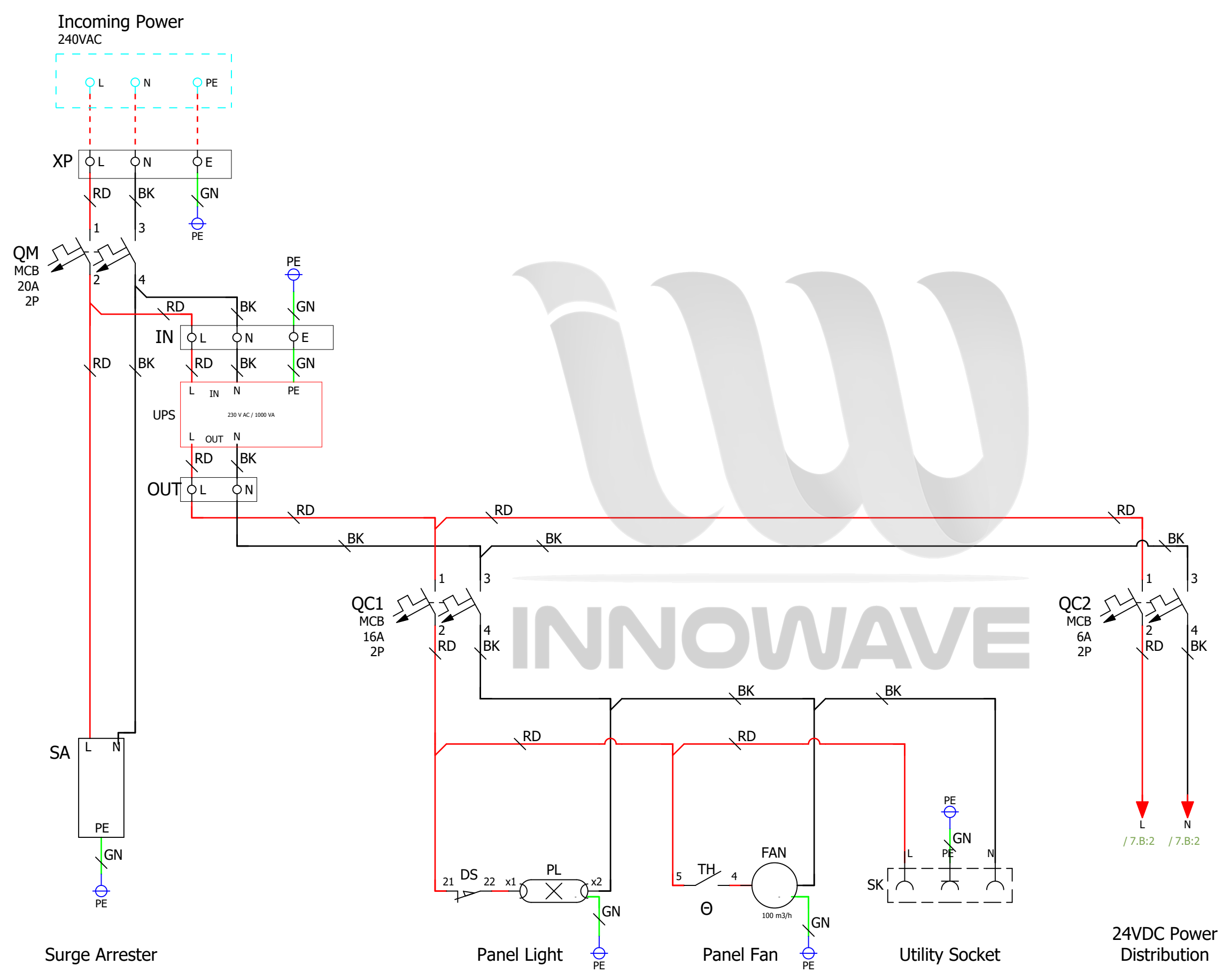

Revision No.	Revision Name	Date	Approved by

**Customer**  
Customer Name & Logo Here

**Contractor**  
Contractor Name & Logo Here

**Company**  
Innovation Wave For Engineering Services  

S.K.U.A

0

1

2

3

4

5

6

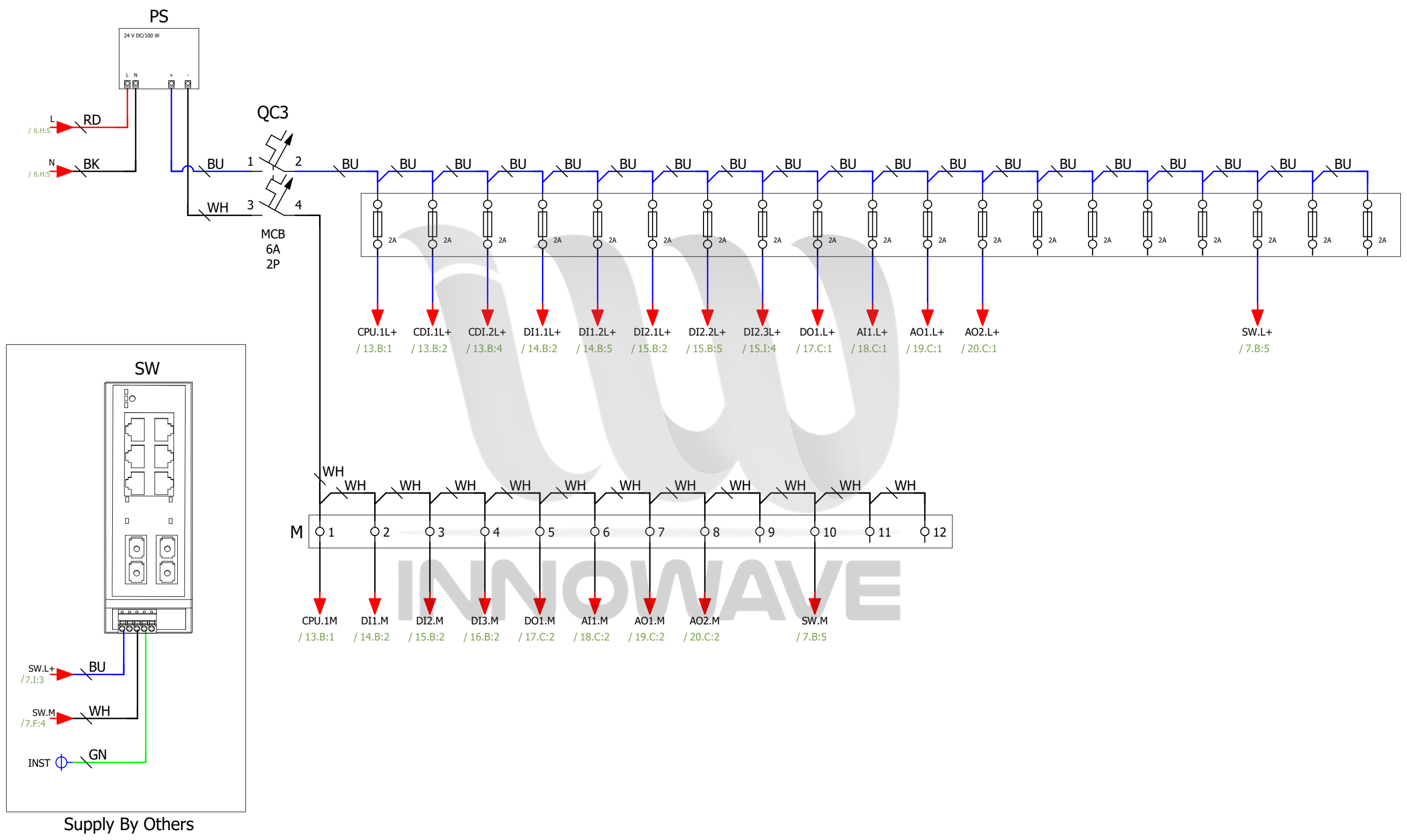

Revision No.	Revision Name	Date	Approved by

**Customer**  
 Customer Name & Logo Here

**Contractor**  
 Contractor Name & Logo Here

**Company**  
 Innovation Wave For Engineering Services



S.K.U.A

0

1

2

3

4

5

6

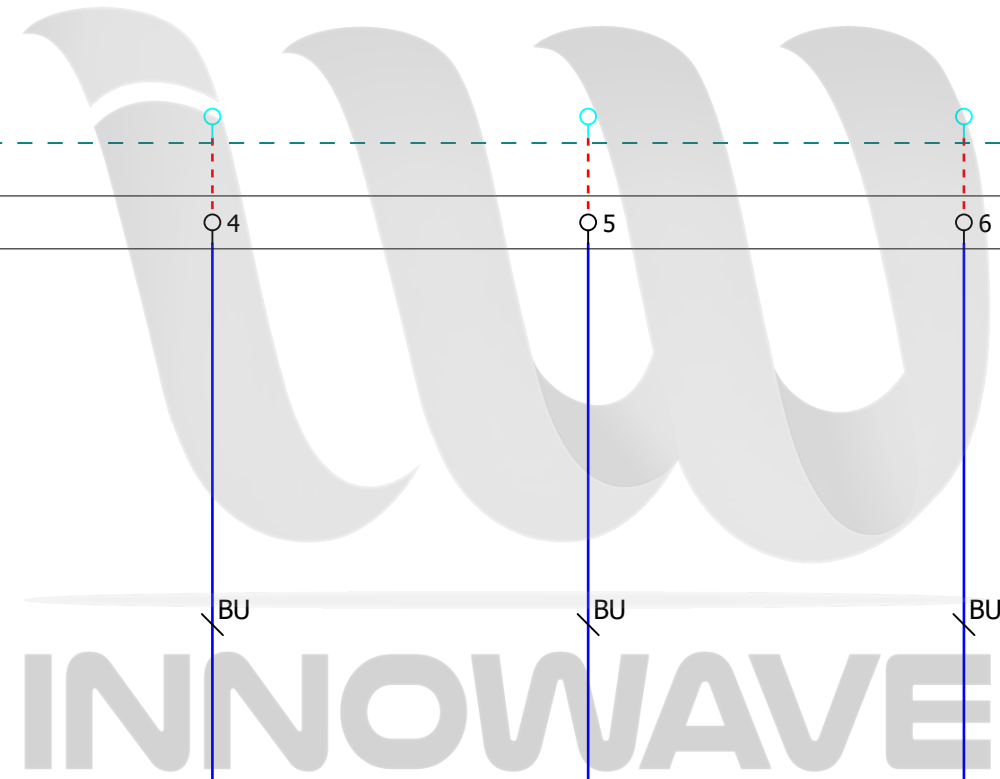
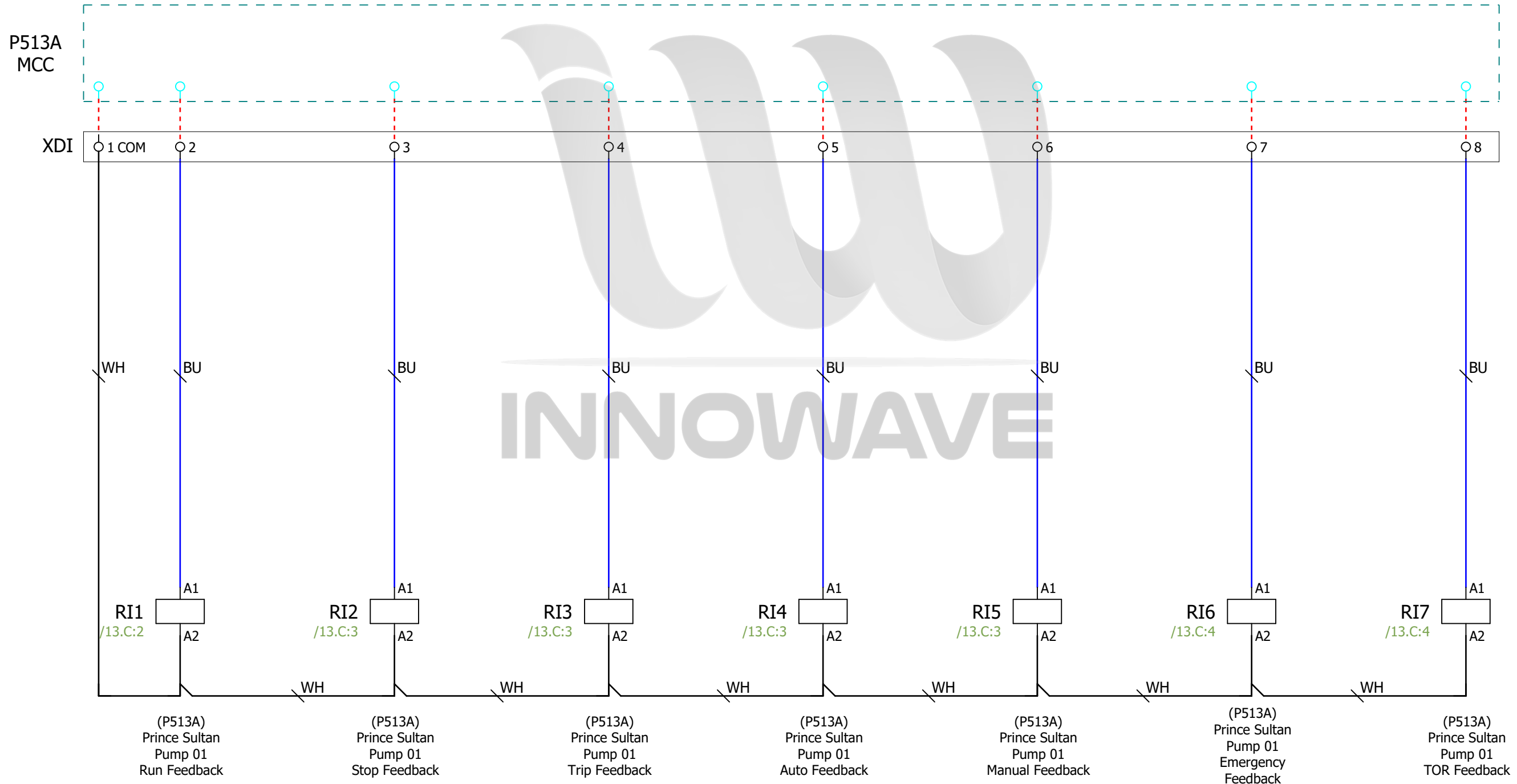

Revision No.	Revision Name	Date	Approved by

**Customer**  
 [Customer Name & Logo Here]

**Contractor**  
 [Contractor Name & Logo Here]

**Company**  
 Innovation Wave For Engineering Services  

S.K.U.A

CP  
 Control Panel  
 (P513A) Prince Sultan P1 W Page 8 / 20



0  
1  
2  
3  
4  
5  
6

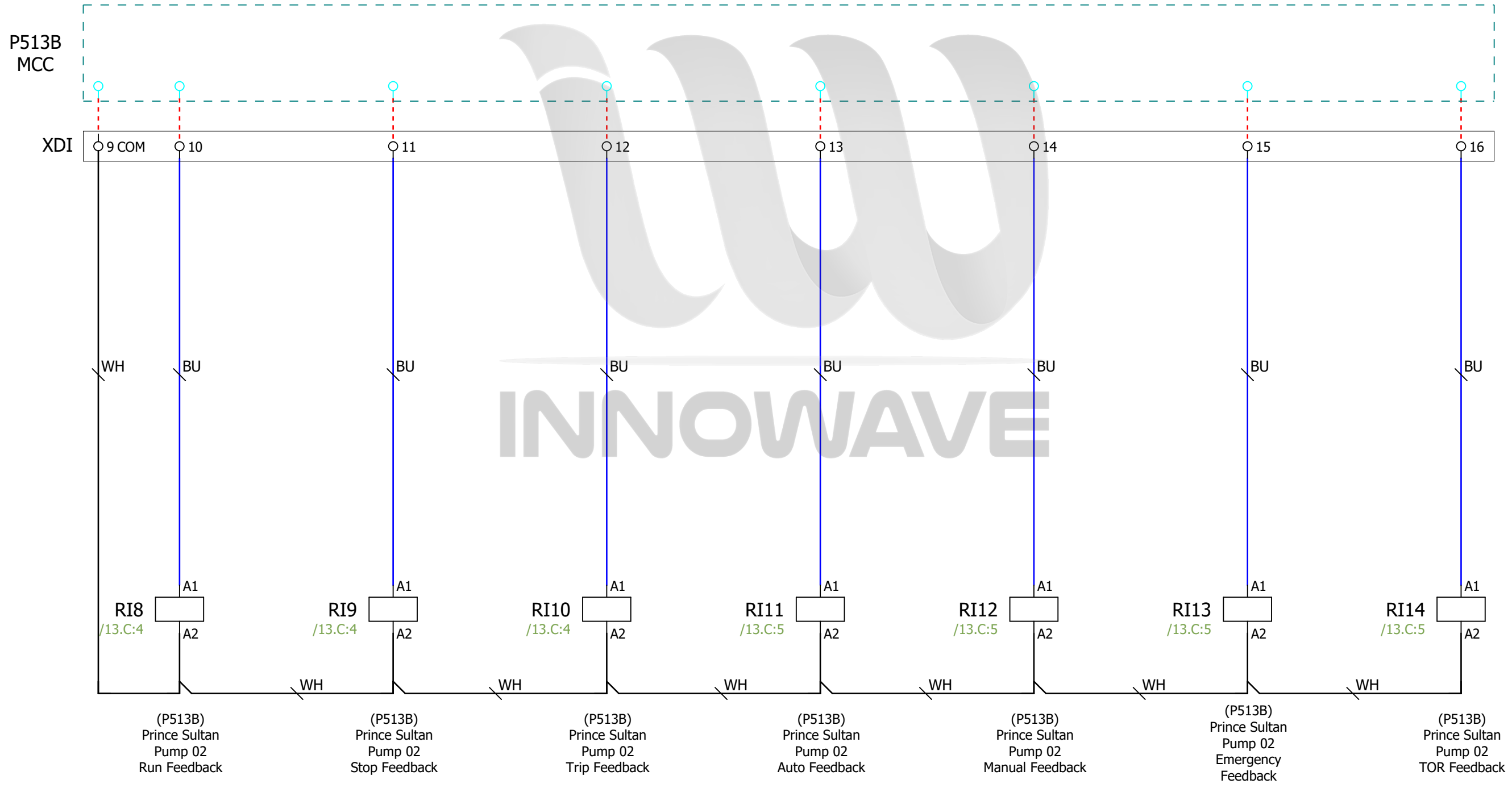

Revision No.	Revision Name	Date	Approved by

**Customer**  
 [Customer Name & Logo Here]

**Contractor**  
 [Contractor Name & Logo Here]

**Company**  
 Innovation Wave For Engineering Services  

S.K.U.A

CP  
 Control Panel  
 (P513B) Prince Sultan P2 W Page 9/20

0  
1  
2  
3  
4  
5  
6

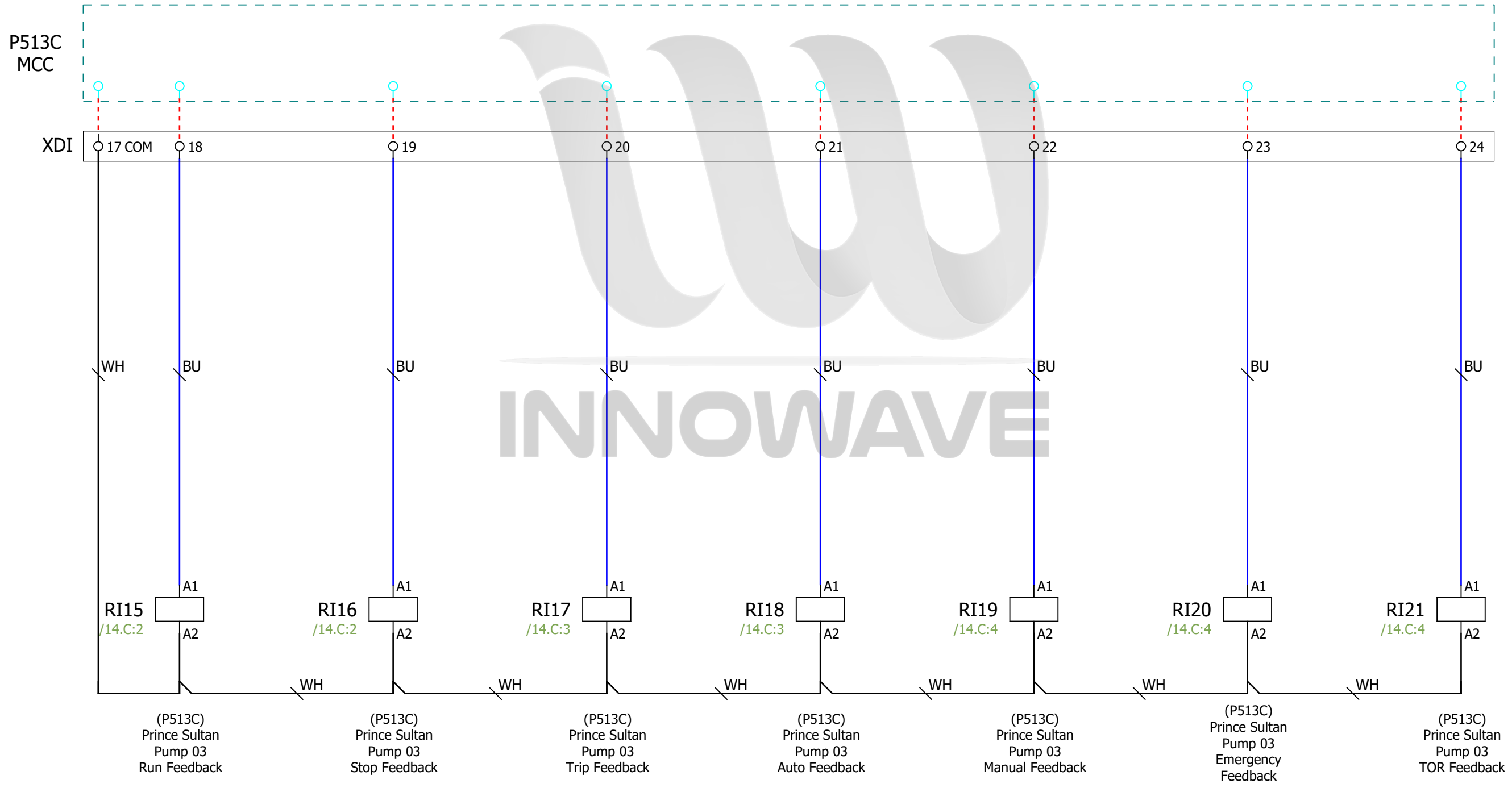

Revision No.	Revision Name	Date	Approved by

**Customer**  
 [Customer Name & Logo Here]

**Contractor**  
 [Contractor Name & Logo Here]

**Company**  
 Innovation Wave For Engineering Services  

S.K.U.A

CP  
 Control Panel  
 (P513C) Prince Sultan P3 W

0

1

2

3

4

5

6

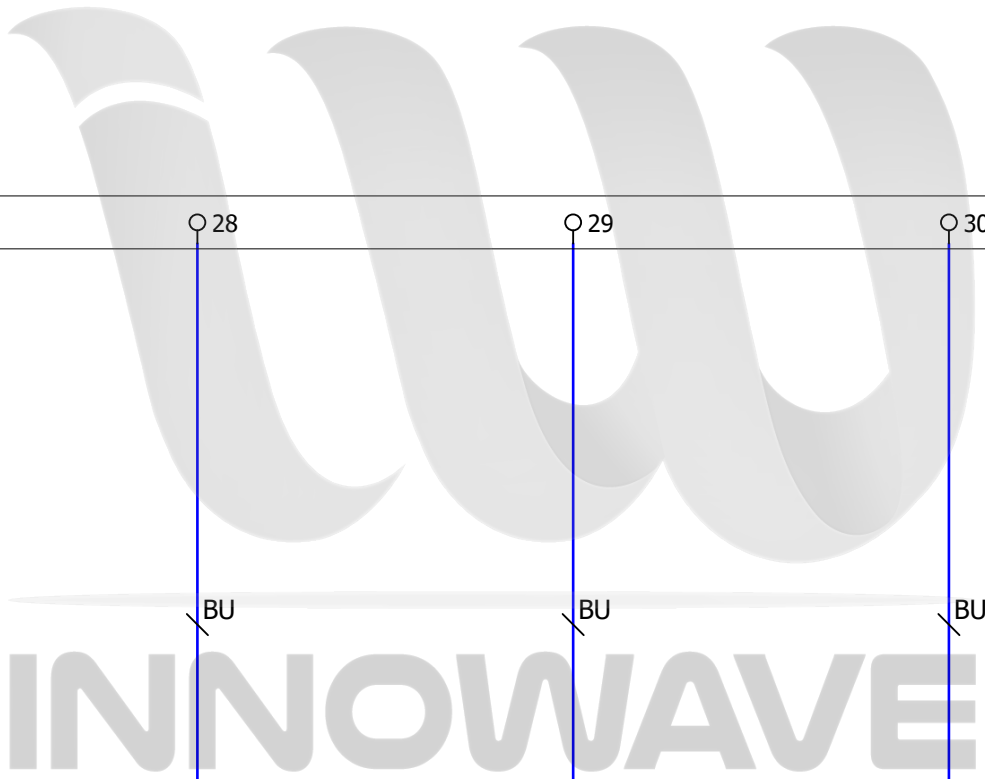
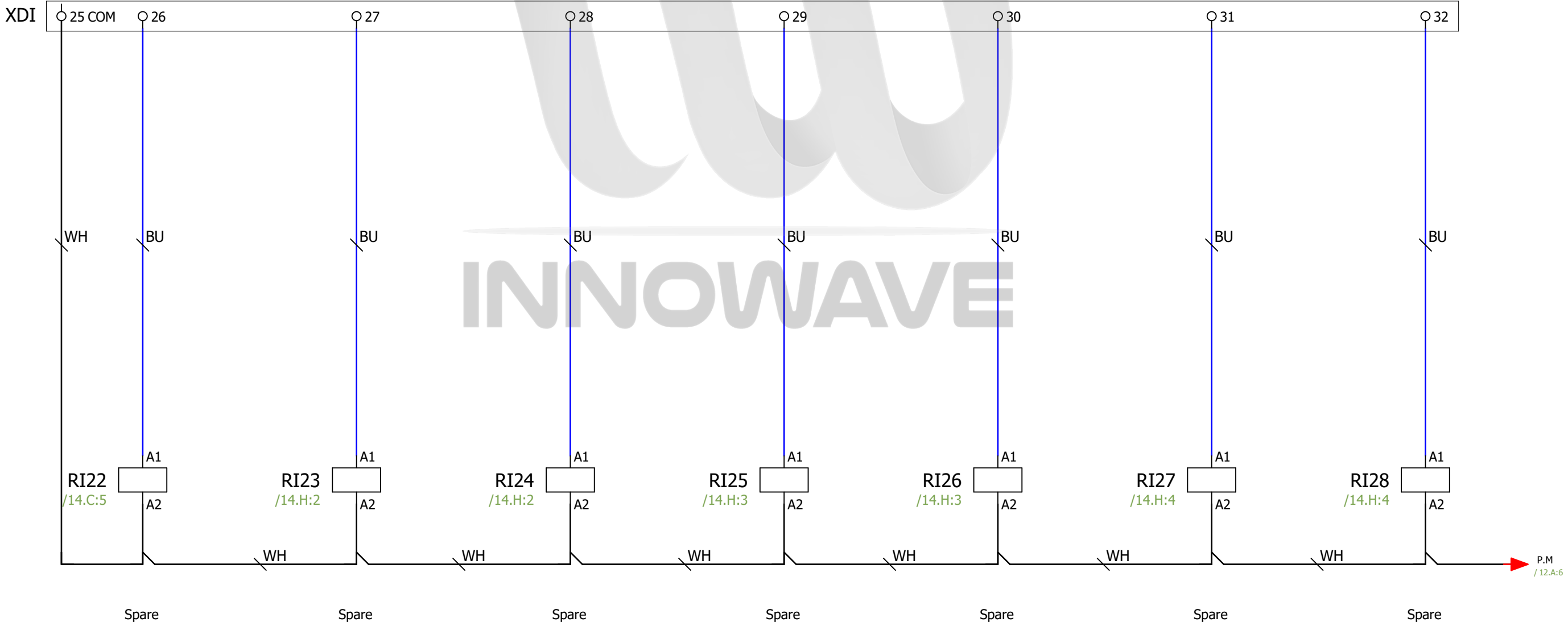

			Edit date	
			Edited by	
			Checked by	
Revision No.	Revision Name	Date	Approved by	

**Customer**  
Customer Name & Logo Here

**Contractor**  
Contractor Name & Logo Here

**Company**  
 Innovation Wave For Engineering Services  
**INNOWAVE**  
Innovation Wave for Engineering Services

S.K.U.A

CP  
 Control Panel  
 Spare DI Wiring Page11 / 20

0  
1  
2  
3  
4  
5  
6

XDI

XDI  33  34

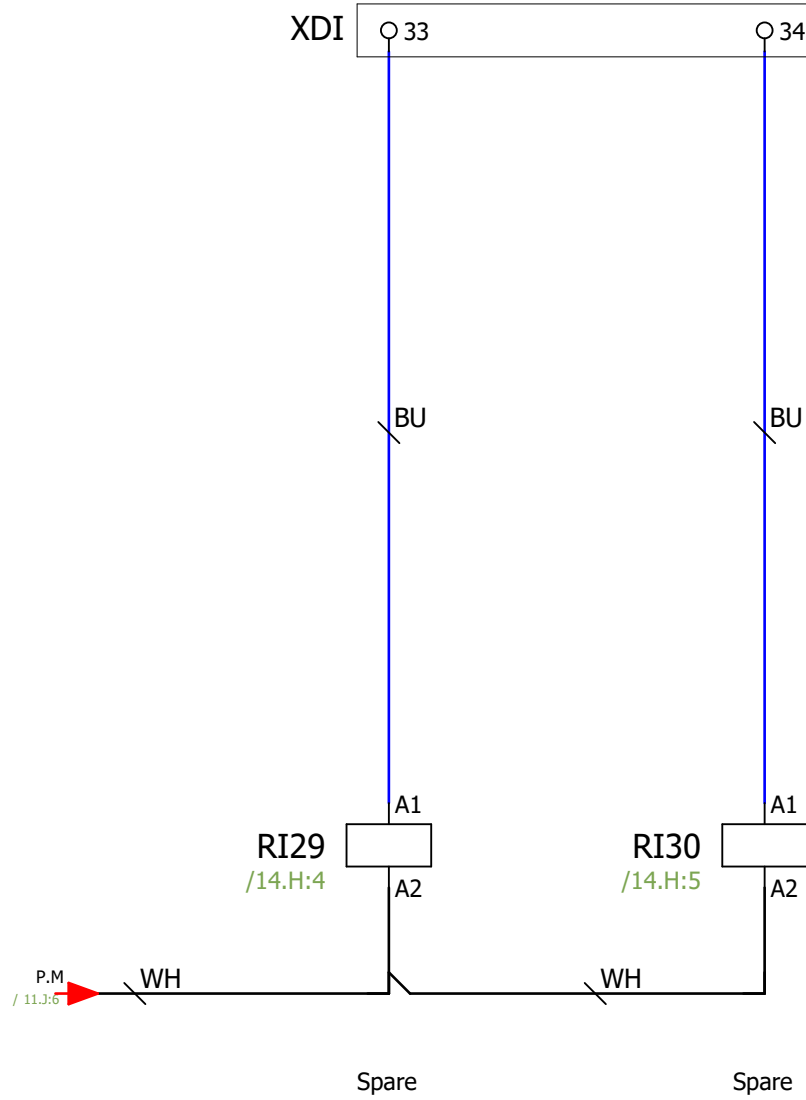

			Edit date	
			Edited by	
			Checked by	
Revision No.	Revision Name	Date	Approved by	

**Customer**

**Contractor**

**Company**  
 Innovation Wave For Engineering Services



S.K.U.A

CP	
Control Panel	
Spare DI Wiring	Page12 / 20

SIE.6ES7214-1HG40-0XB0

CPU 1214 - 14DI/10DO/2AI

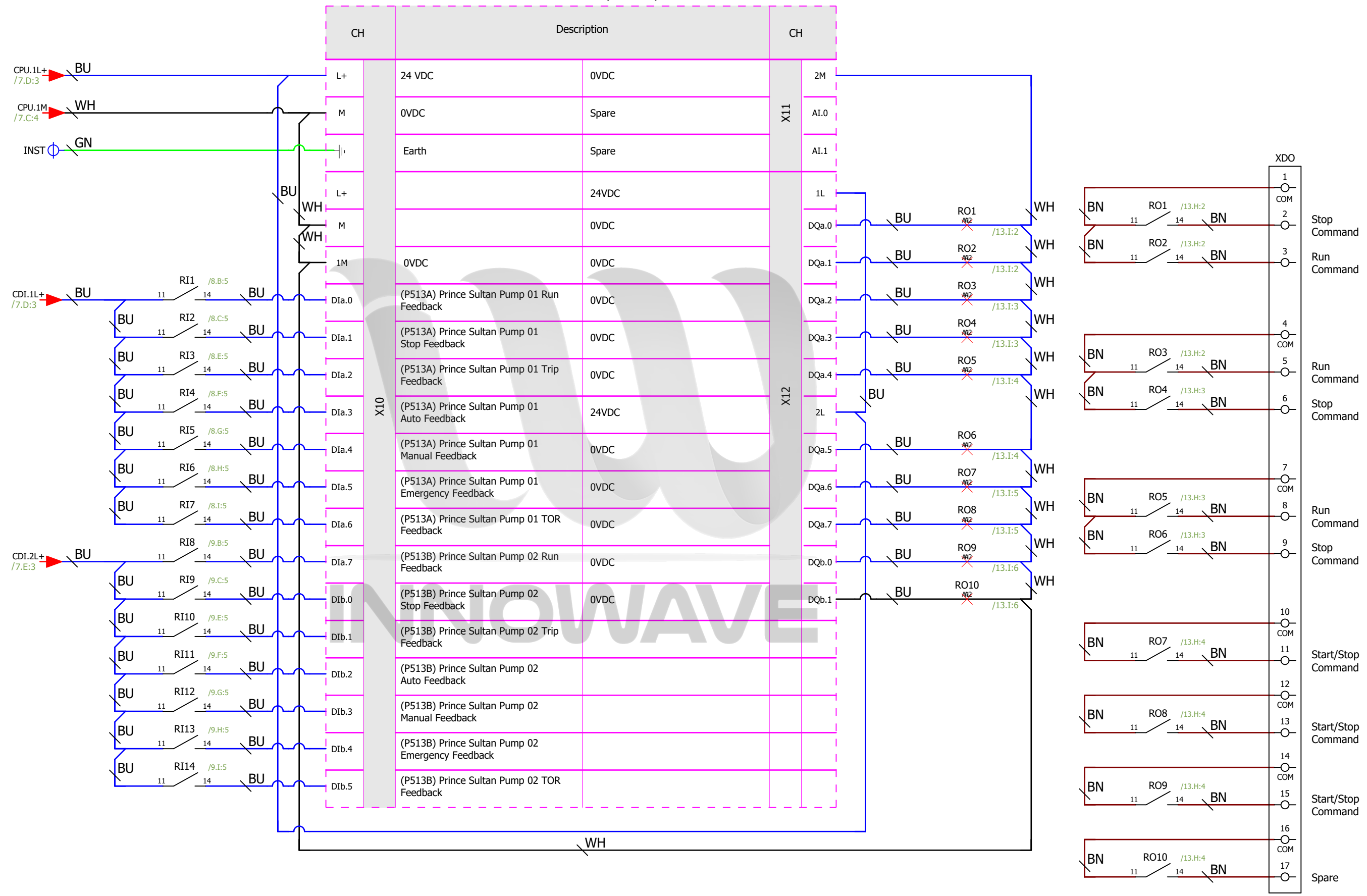

Revision No.	Revision Name	Date	Approved by

Customer	Customer Name & Logo Here
----------	---------------------------

Contractor	Contractor Name & Logo Here
------------	-----------------------------

Company	Innovation Wave For Engineering Services	
---------	--	--

S.K.U.A
---------

CP	Control Panel	Page13 / 20
CPU Wiring		

SIE.6ES7221-1BH32-0XB0

### DI1 SM 1221- Digital Input - 16 DI

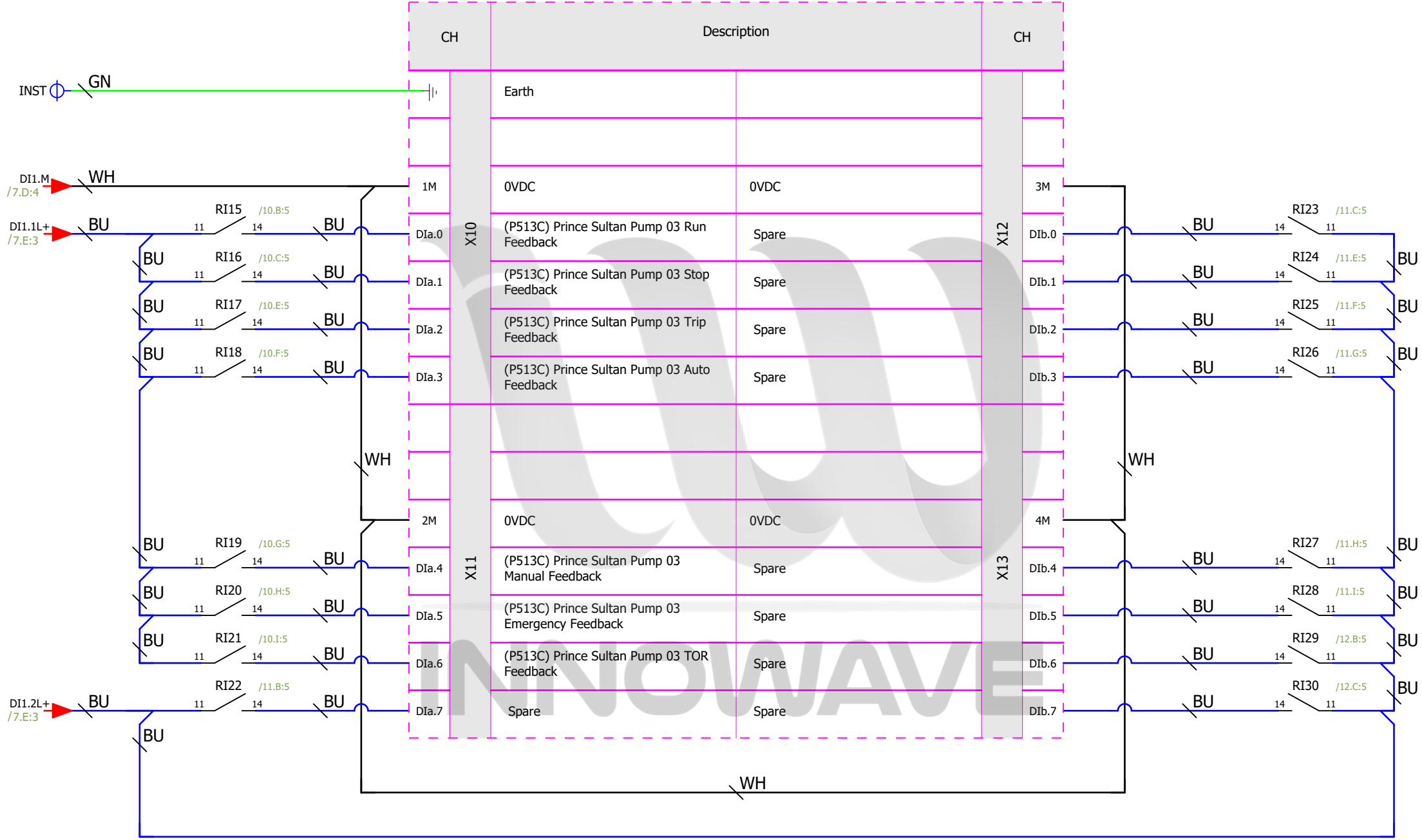

Revision No.	Revision Name	Date	Approved by

**Customer**  
 Customer Name & Logo Here

**Contractor**  
 Contractor Name & Logo Here

**Company**  
 Innovation Wave For Engineering Services  

S.K.U.A

SIE.6ES7221-1BH32-0XB0

DI2 SM 1221- Digital Input - 16 DI

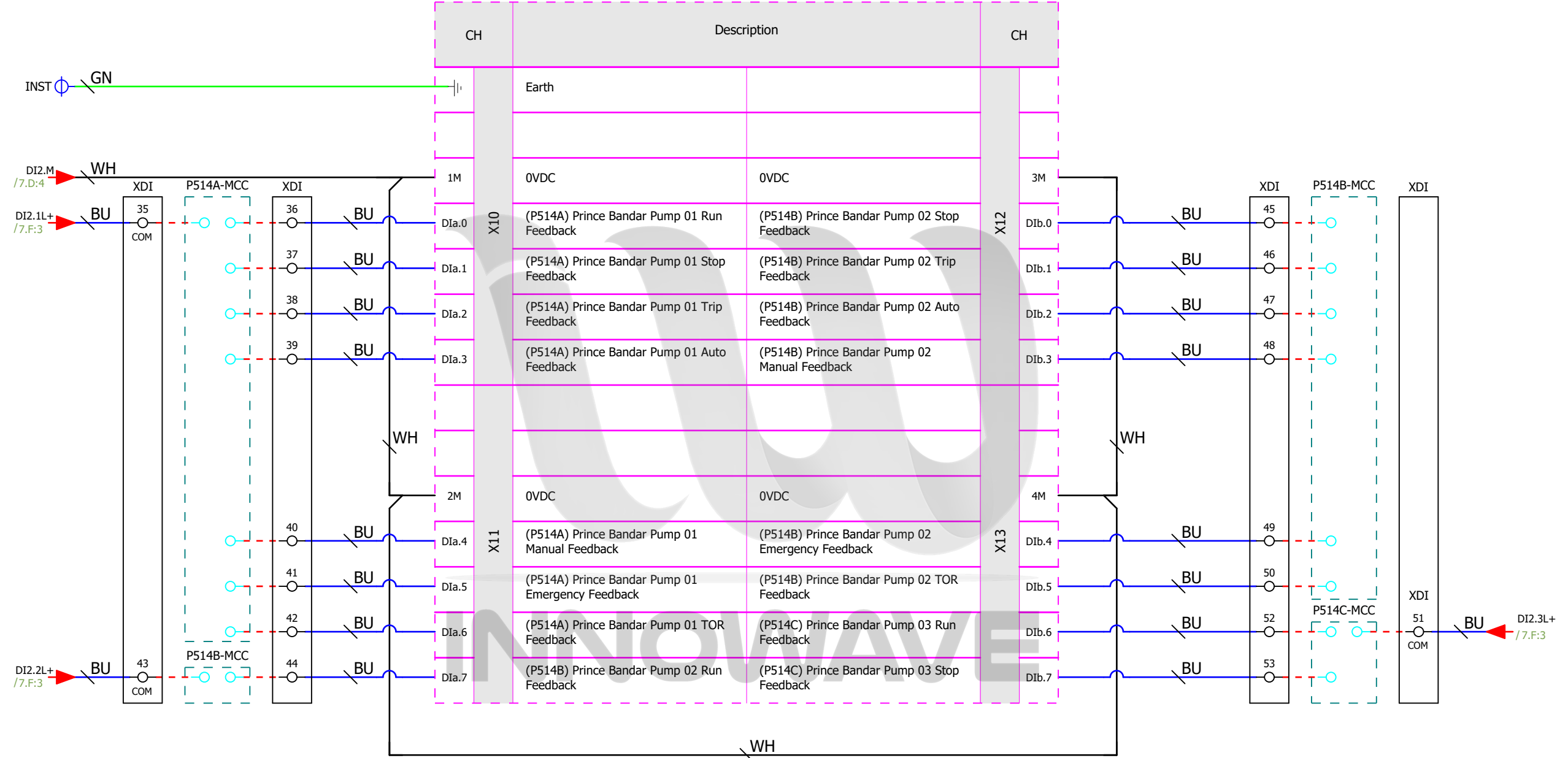

Revision No.	Revision Name	Date	Approved by

**Customer**  
 Customer Name & Logo Here

**Contractor**  
 Contractor Name & Logo Here

**Company**  
 Innovation Wave For Engineering Services

S.K.U.A  
 CP  
 Control Panel  
 DI-2 Wiring

SIE.6ES7221-1BH32-0XB0

### DI3 SM 1221- Digital Input - 16 DI

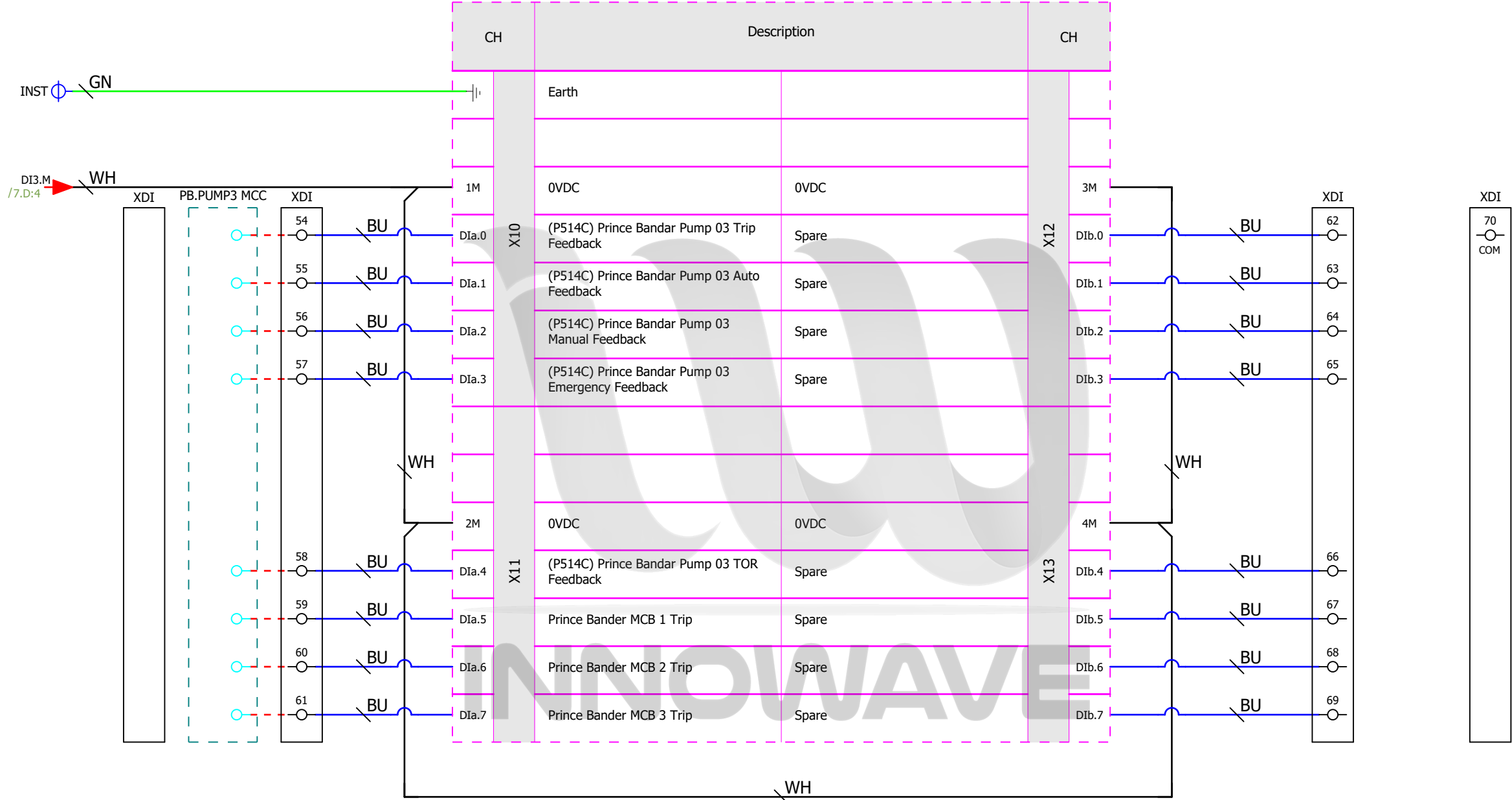

			Edit date
			Edited by
			Checked by
Revision No.	Revision Name	Date	Approved by

**Customer**  
Customer Name & Logo Here

**Contractor**  
Contractor Name & Logo Here

**Company**  
 Innovation Wave For Engineering Services  



S.K.U.A  
 CP



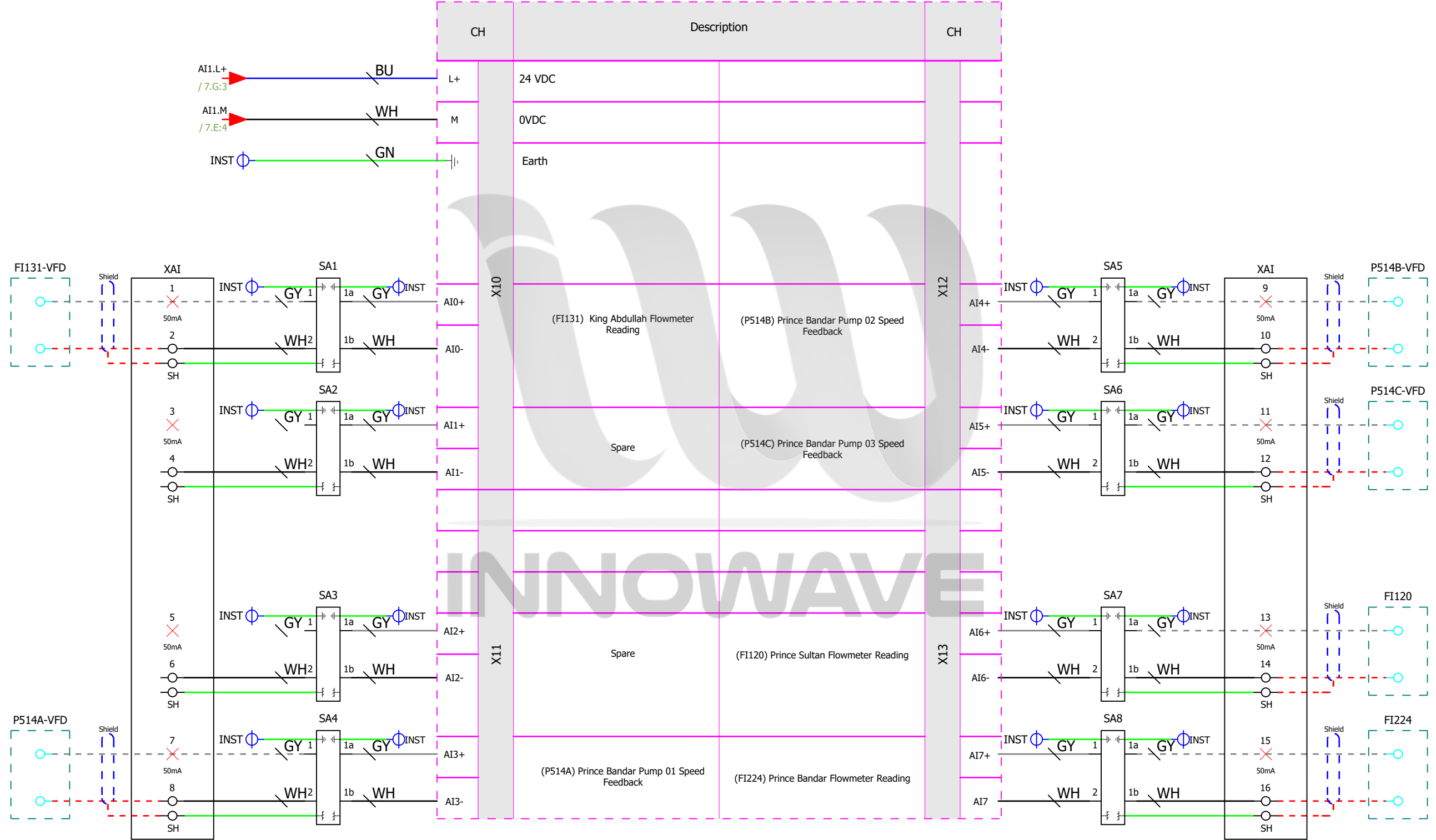

SIE.6ES7231-4HF32-0XB0

### AI1 SM 1231, Analog Input, 8 AI



Revision No.	Revision Name	Date	Approved by

**Customer**

**Contractor**

**Company**  
 Innovation Wave For Engineering Services  

S.K.U.A

CP  
 Control Panel

SIE.6ES7232-4HD32-0XB0

AO1 SM 1232 - Analog Output - AO 4

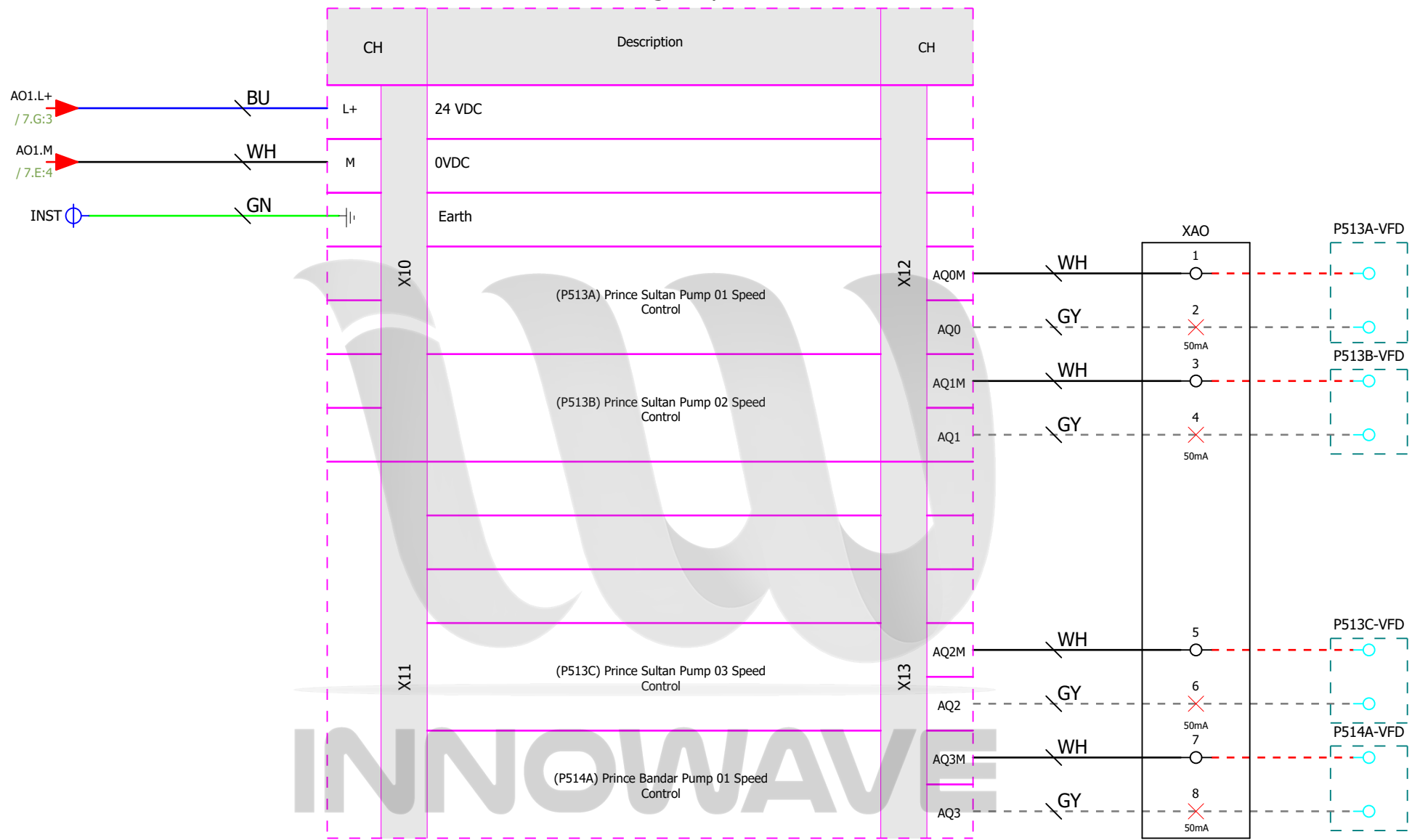

			Edit date
			Edited by
			Checked by
Revision No.	Revision Name	Date	Approved by

**Customer**  
 Customer Name & Logo Here

**Contractor**  
 Contractor Name & Logo Here

**Company**  
 Innovation Wave For Engineering Services  

S.K.U.A

SIE.6ES7232-4HD32-0XB0

AO2 SM 1232 - Analog Output - AO 4

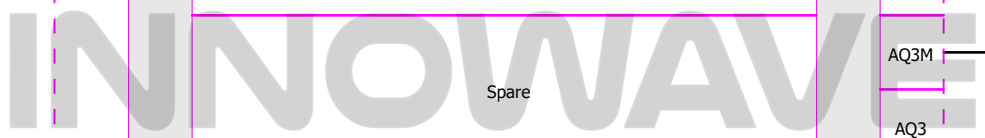
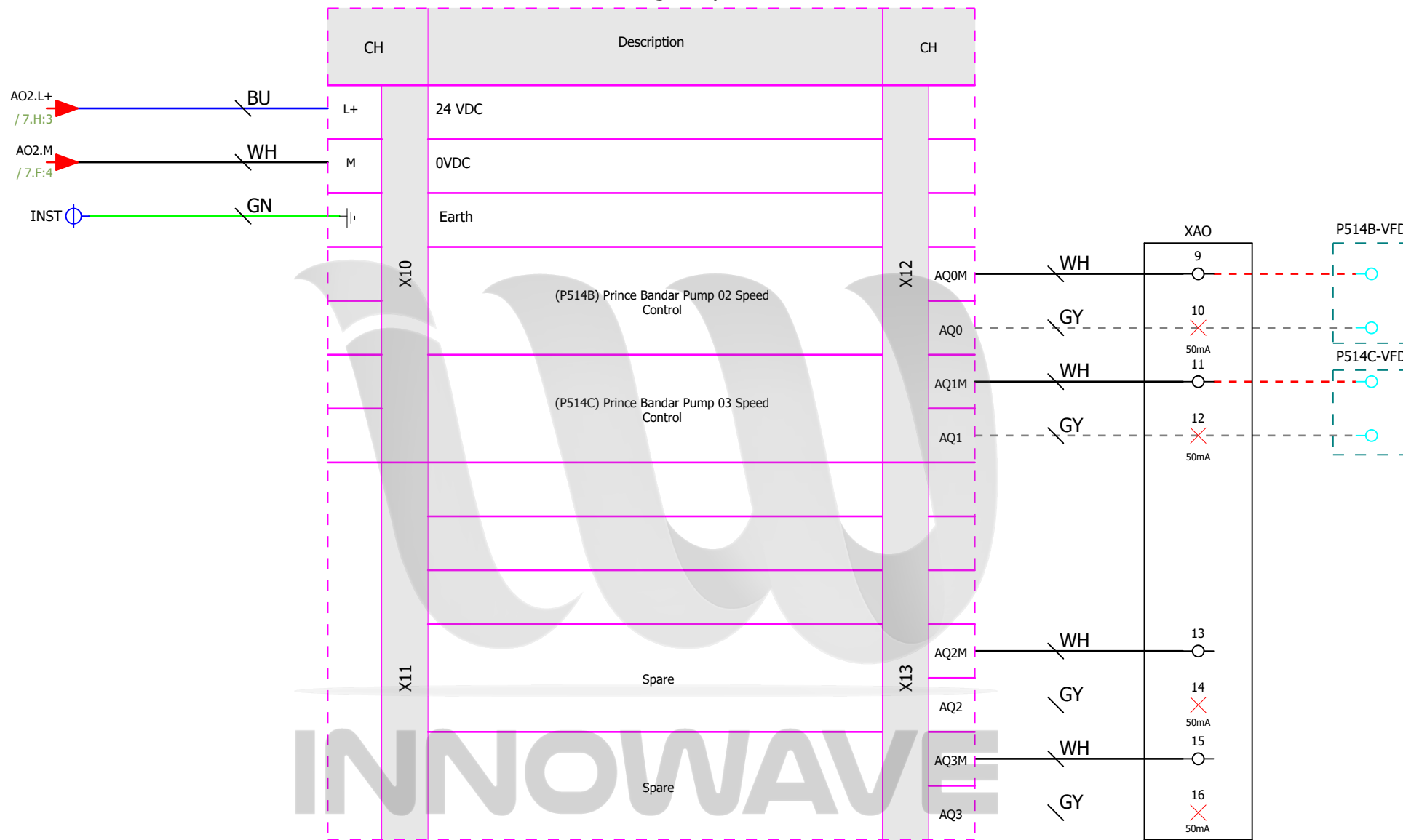

			Edit date
			Edited by
			Checked by
Revision No.	Revision Name	Date	Approved by

**Customer**  
 Customer Name & Logo Here

**Contractor**  
 Contractor Name & Logo Here

**Company**  
 Innovation Wave For Engineering Services

S.K.U.A